



Model : 54/2024



F-14 Tomcat

1860 mm (swept out)

Specs

1. Wingspan 1860mm / 73.2 inches
2. Flying weight : 3000 grams/ 105.8 oz/ 6.6 lbs
3. Wing loading : 46.9 gram/dm² - 15.4 oz/sq.ft.
4. Wing cube loading : 5.9 (Trainer)
5. Wing Area : 63.95 dm² / 991 sq.in.
6. CG : Check plans

Electronics

- 2X FMS 70mm 1900kv 12 blades EDF
- 2X Hobbywing 80A ESC
- 6S 5600mah Lipo Battery
- 4X 9 gram servo
- 2X Standard Servo 6.5kg torque

Transmitter

- Jumper T16 + BetaFPV Express LRS TX module
- 10 ch BetaFPV Express LRS RX
- Flight Stabilization (Gyro) A3V2

Materials :

1. 6mm Foamboard/ Depron/ Polyfoam
2. Bamboo Chopstik
3. 5mm Carbon Tube/ Bamboo
4. 0.5mm Mica Plastic
5. hot glue, UHU glue, CA glue, PVA glue
6. Packing tapes

Inch



Centimeter



Build Instructions :

1. paper-replika.com
2. youtube channel : Julius Perdana

F2

NOSE
POLYFOAM/
DEPRON 5MM

FRONT



F4

NOSE
POLYFOAM/
DEPRON 5MM

FRONT





F6

NOSE
POLYFOAM/
DEPRON 5MM

JOIN HERE

F5

NOSE FORMER
POLYFOAM/
DEPRON 5MM

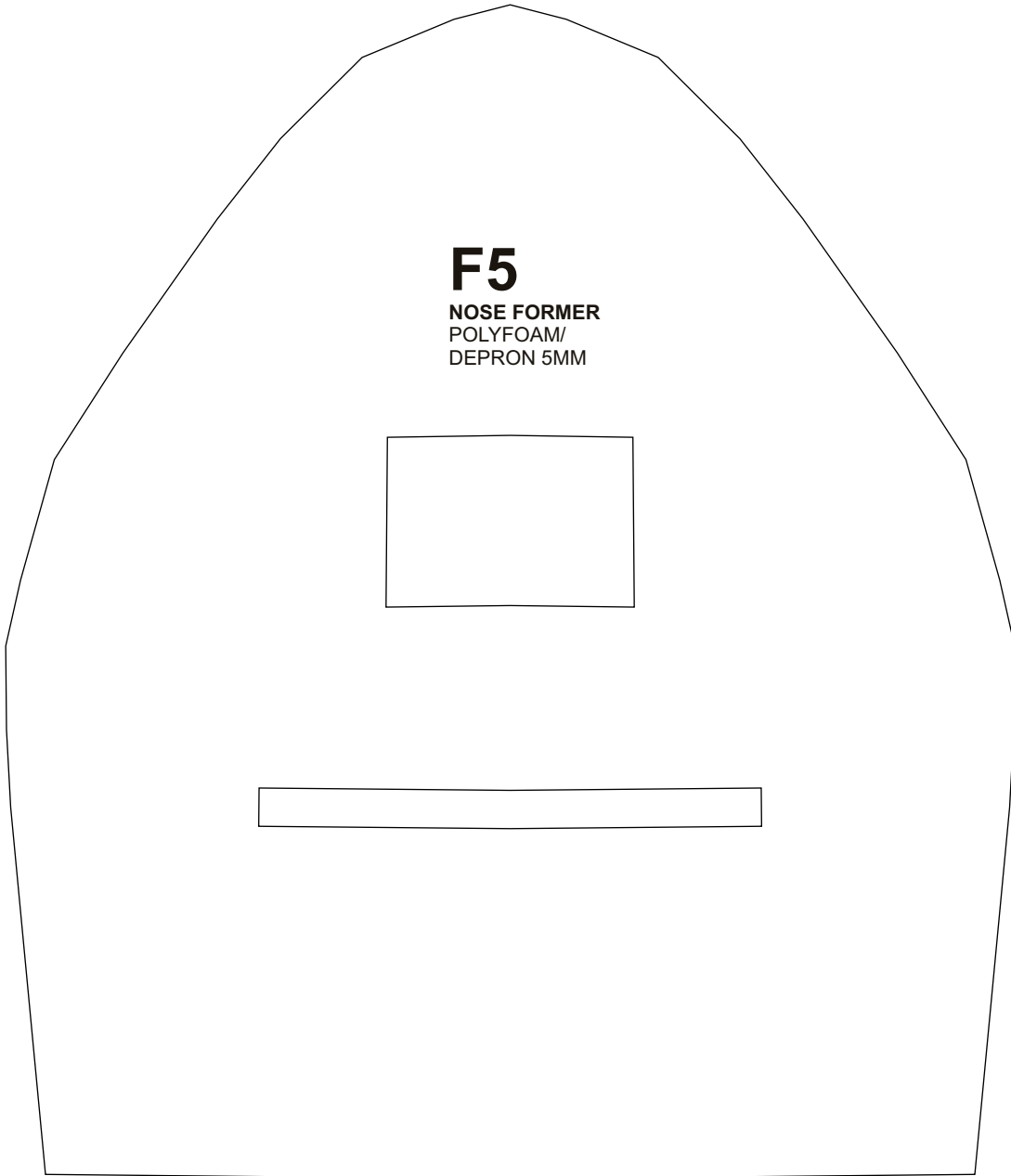
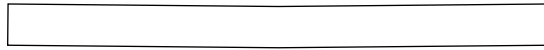
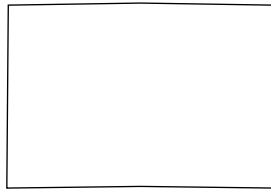



F6

JOIN HERE

JOIN HERE

F6

JOIN HERE

F3

NOSE FORMER
POLYFOAM/
DEPRON 5MM

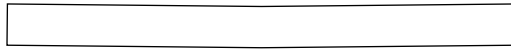

JOIN HERE

JOIN HERE

F6

JOIN HERE

F6

JOIN HERE

F10

NOSE FORMER
POLYFOAM/
DEPRON 5MM

F7

NOSE
POLYFOAM/
DEPRON 5MM

JOIN HERE

JOIN HERE

F7

FRONT





F8

NOSE
POLYFOAM/
DEPRON 5MM

JOIN HERE

JOIN HERE

F8

F11

NOSE
POLYFOAM/
DEPRON 5MM
17X



F9

NOSE
POLYFOAM/
DEPRON 5MM

JOIN HERE

JOIN HERE

F9

F1

NOSE FORMER
POLYFOAM/
DEPRON 5MM

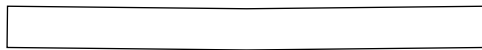

F13

FUSELAGE
POLYFOAM/
DEPRON 5MM

F12

FUSELAGE
POLYFOAM/
DEPRON 5MM

JOIN HERE

JOIN HERE

JOIN HERE

JOIN HERE

JOIN HERE

F12

JOIN HERE

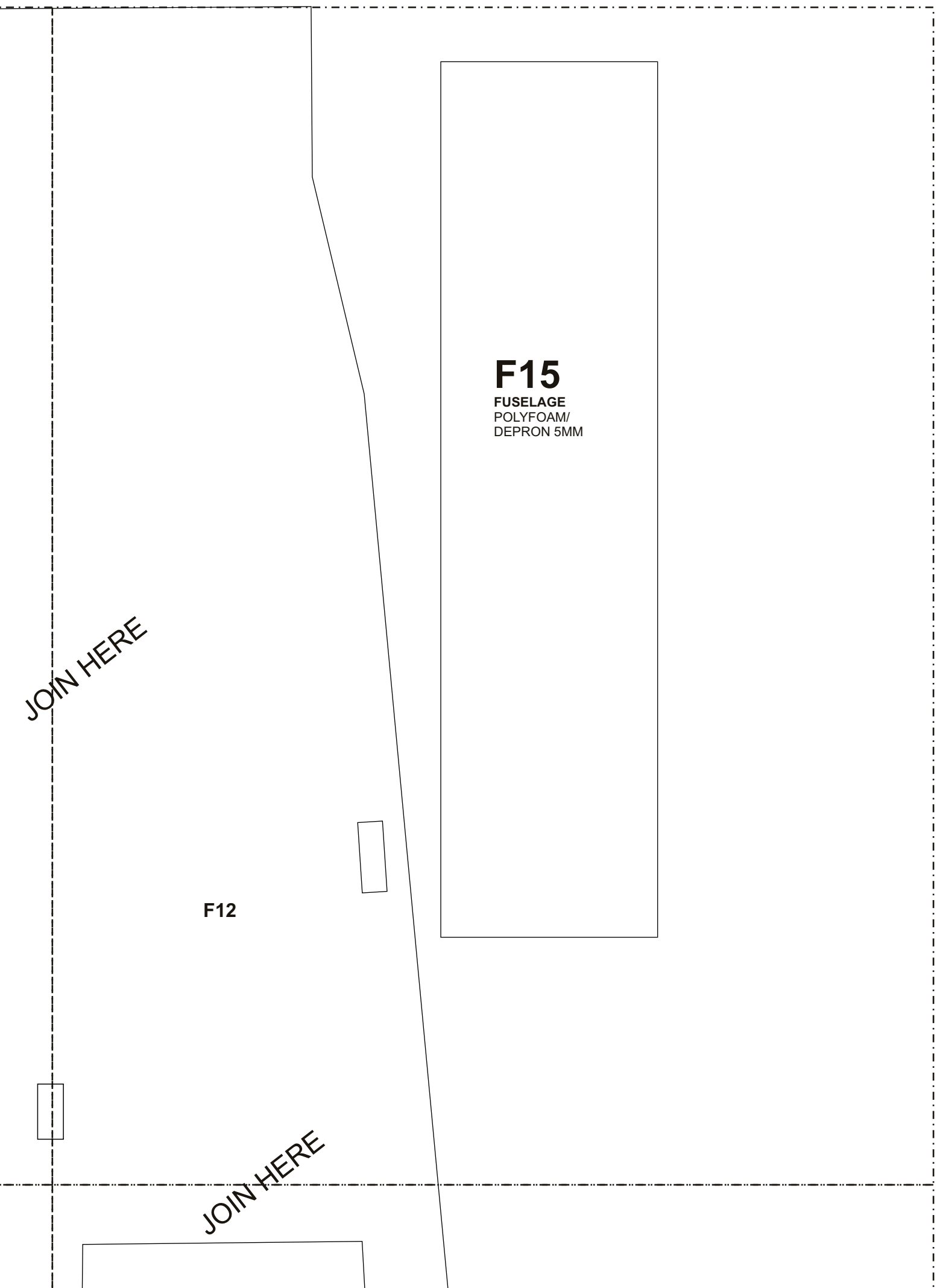

F15

FUSELAGE
POLYFOAM/
DEPRON 5MM

F12

JOIN HERE

JOIN HERE

JOIN HERE

JOIN HERE

JOIN HERE

JOIN HERE

F14

FUSELAGE
POLYFOAM/
DEPRON 5MM
2X MIRRORED

F12

JOIN HERE

F12

JOIN HERE

JOIN HERE

JOIN HERE

JOIN HERE

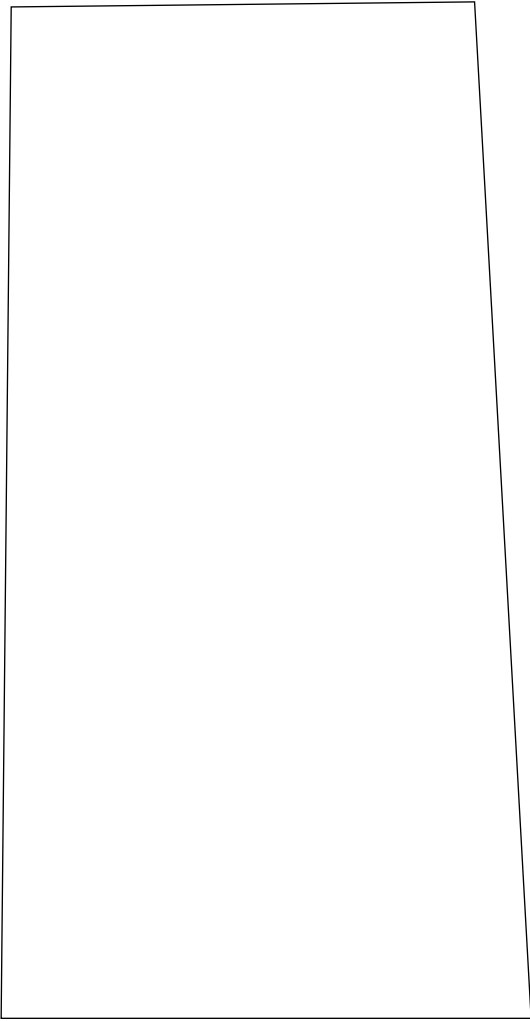

JOIN HERE

F12

JOIN HERE



JOIN HERE



F12

JOIN HERE

JOIN HERE

F12

JOIN HERE

JOIN HERE

JOIN HERE



F12

JOIN HERE

F32

FUSELAGE FORMER
POLYFOAM/
DEPRON 5MM
2X MIRRORED

F16

FUSELAGE
POLYFOAM/
DEPRON 5MM

JOIN HERE

JOIN HERE

JOIN HERE

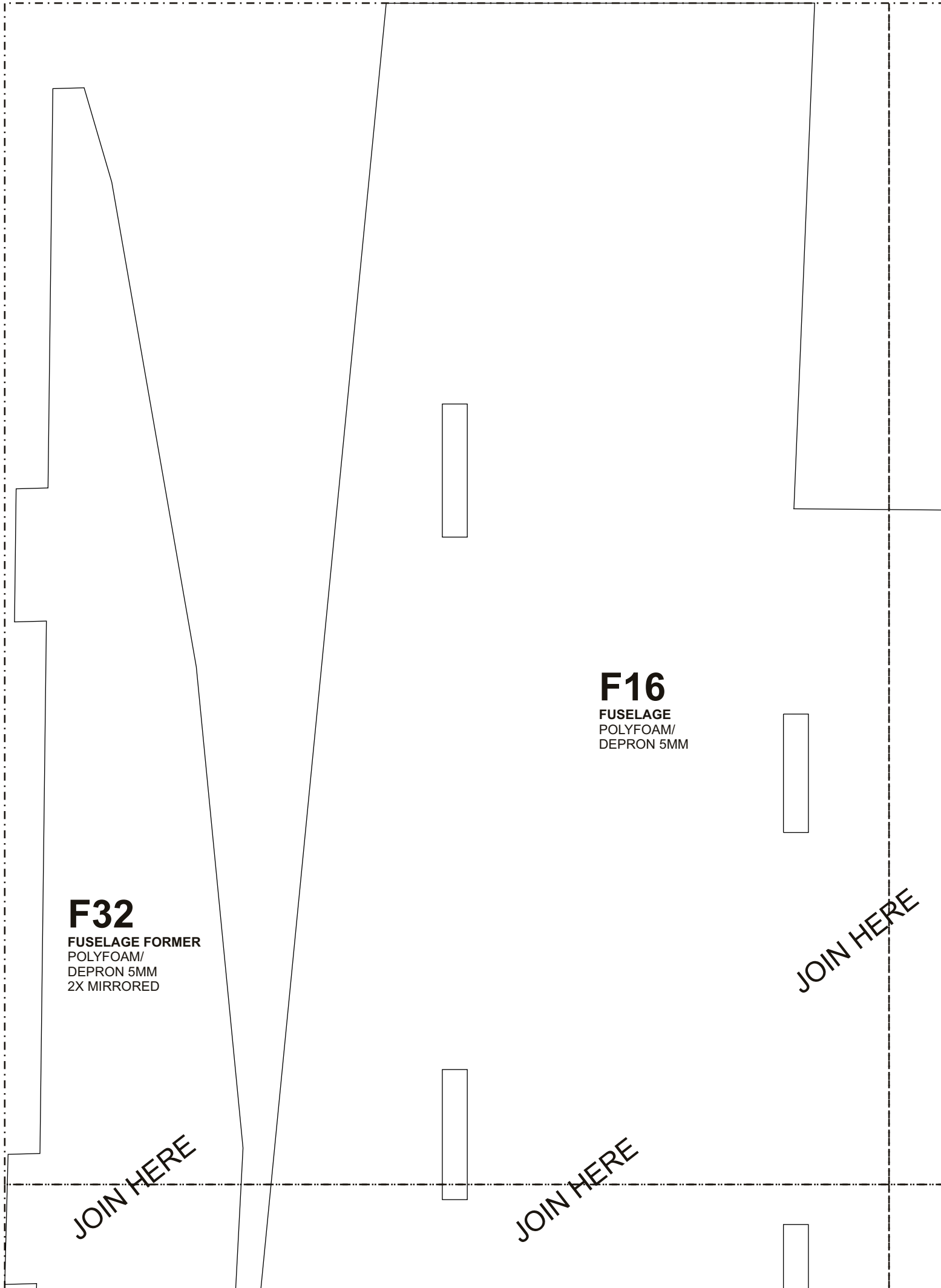

F24

HOR-STAB MOUNTING
POLYFOAM/
DEPRON 5MM
6X MIRRORED

F16

JOIN HERE

JOIN HERE

JOIN HERE

F21

EDF MOUNTING
POLYFOAM/
DEPRON 5MM
2X MIRRORED

F22

EDF MOUNTING
POLYFOAM/
DEPRON 5MM
6X MIRRORED

F16

F20

F33

JOIN HERE

JOIN HERE

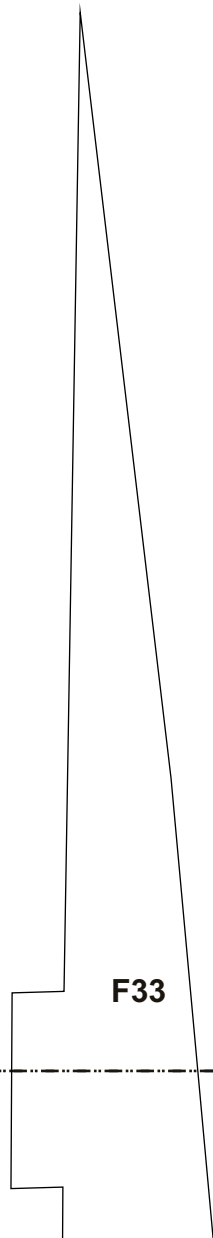
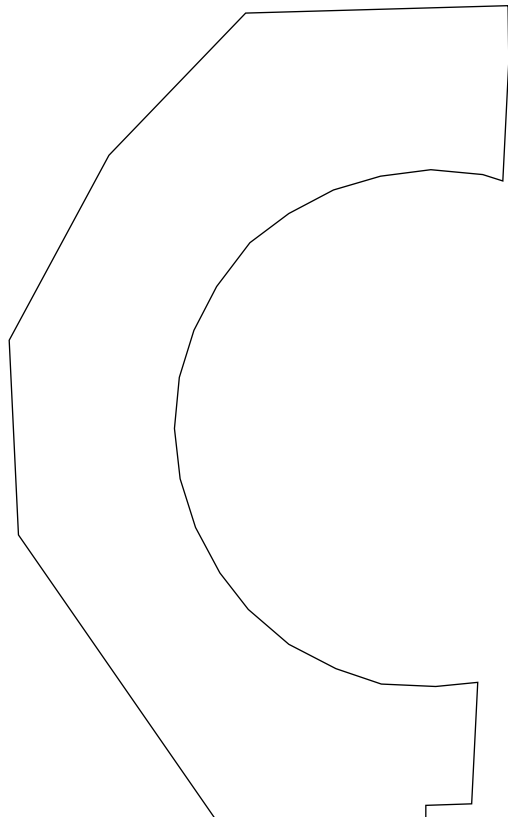
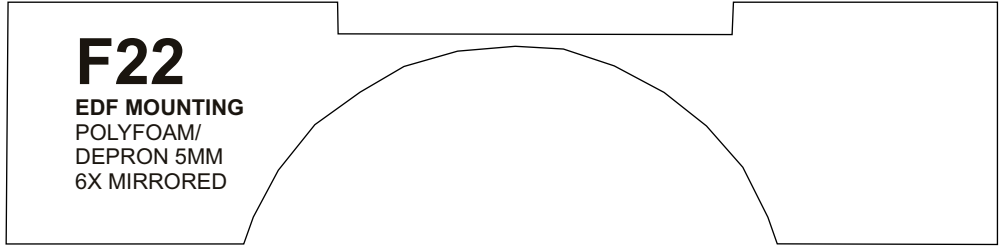
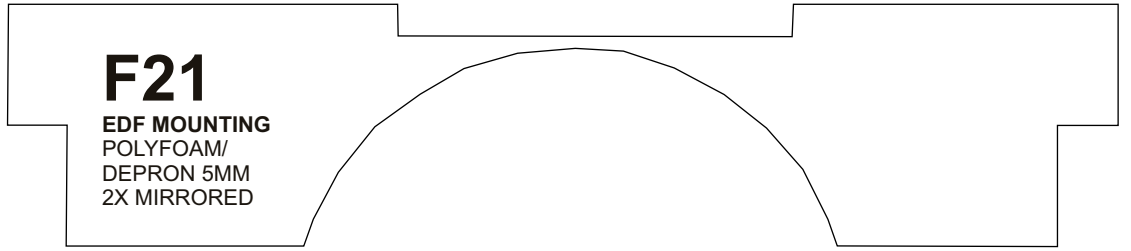

JOIN HERE

JOIN HERE

F32

F16

JOIN HERE

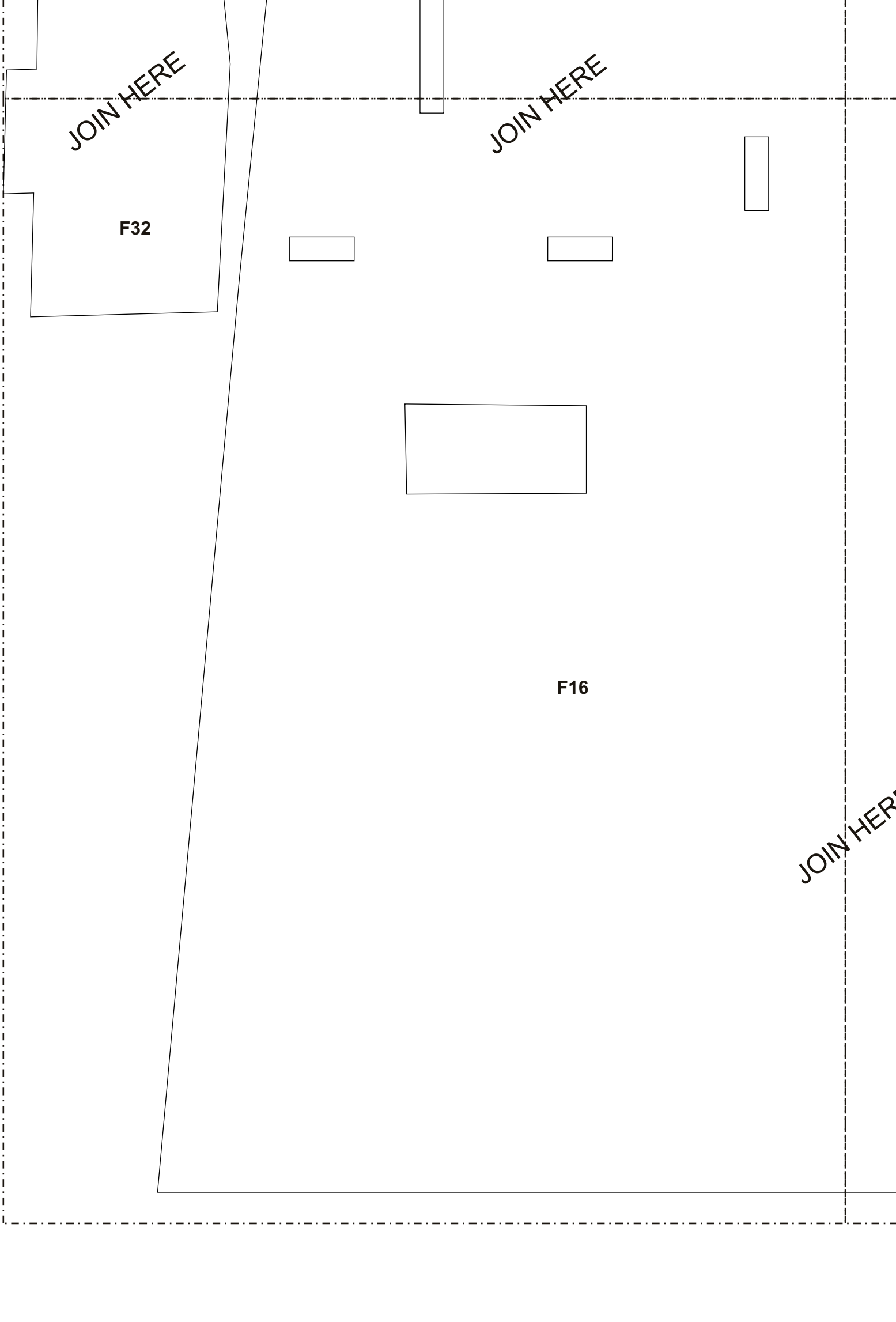

JOIN HERE

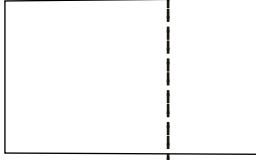

F16

JOIN HERE

JOIN HERE

JOIN HERE

F33

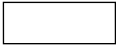

F20

FUSELAGE
POLYFOAM/
DEPRON 5MM

F33

FUSELAGE
POLYFOAM/
DEPRON 5MM
2X MIRRORED

F16

JOIN HERE

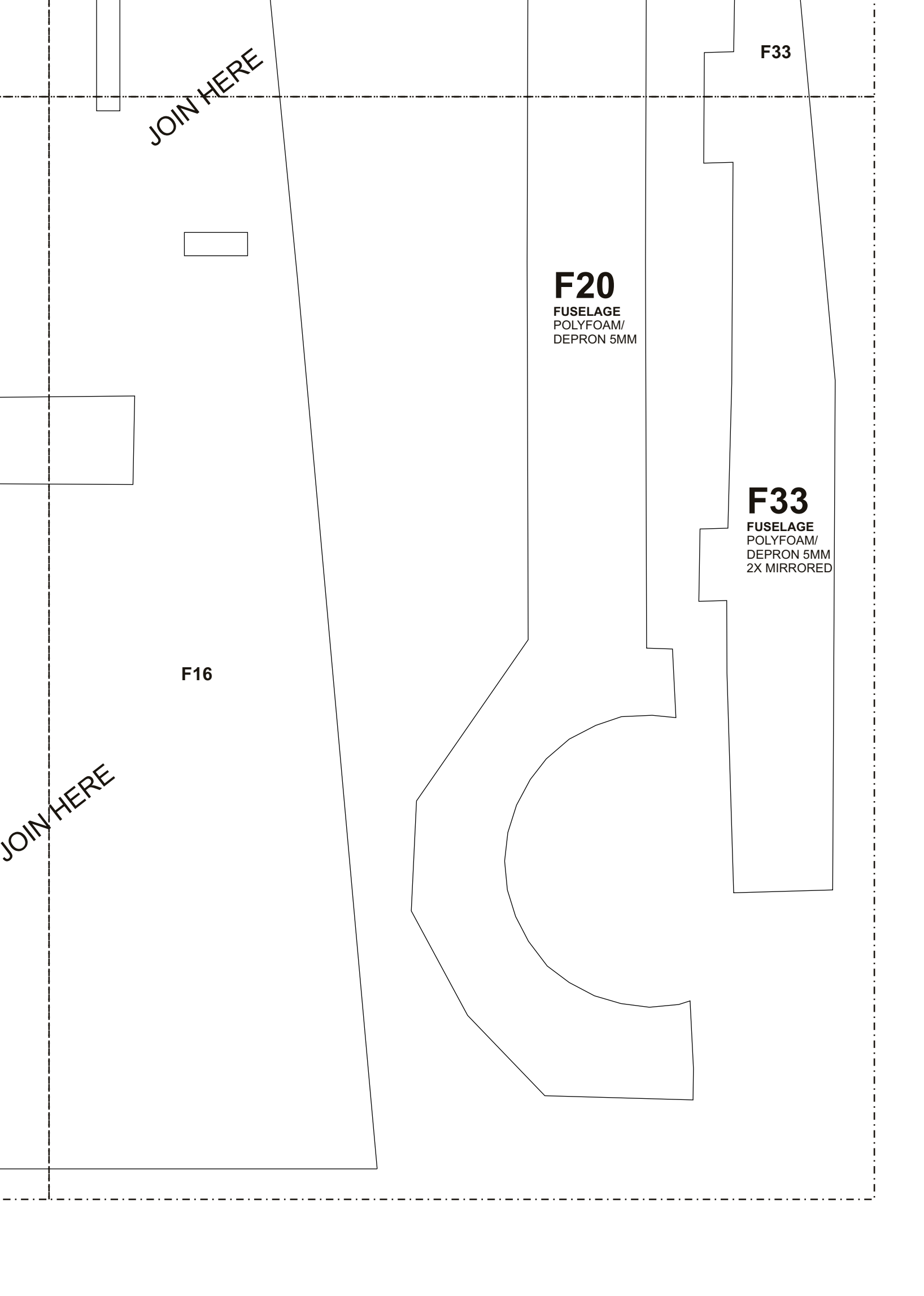

F19

FUSELAGE
POLYFOAM/
DEPRON 5MM
2X MIRRORED

F17

FUSELAGE
POLYFOAM/
DEPRON 5MM

JOIN HERE

JOIN HERE

JOIN HERE

JOIN HERE

F17

JOIN HERE



JOIN HERE

F17

F18

JOIN HERE

JOIN HERE

JOIN HERE

F19

F17

F28
FUSELAGE
POLYFOAM/
DEPRON 5MM
2X MIRRORED



FRONT



JOIN HERE

F17

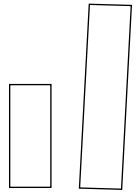
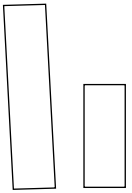

JOIN HERE

JOIN HERE

F27

VER-STAB MOUNTING
POLYFOAM/
DEPRON 5MM
6X MIRRORED

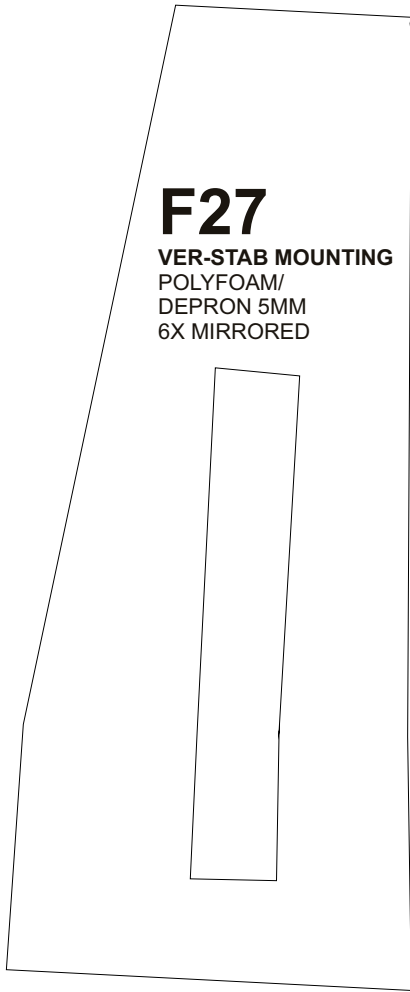

F17

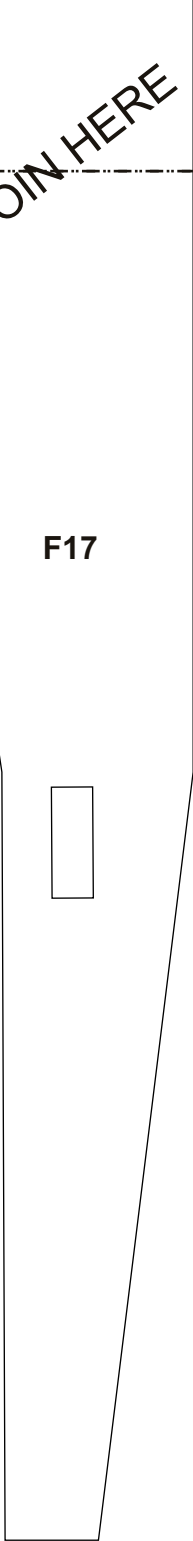

F18

FUSELAGE
POLYFOAM/
DEPRON 5MM
2X MIRRORED

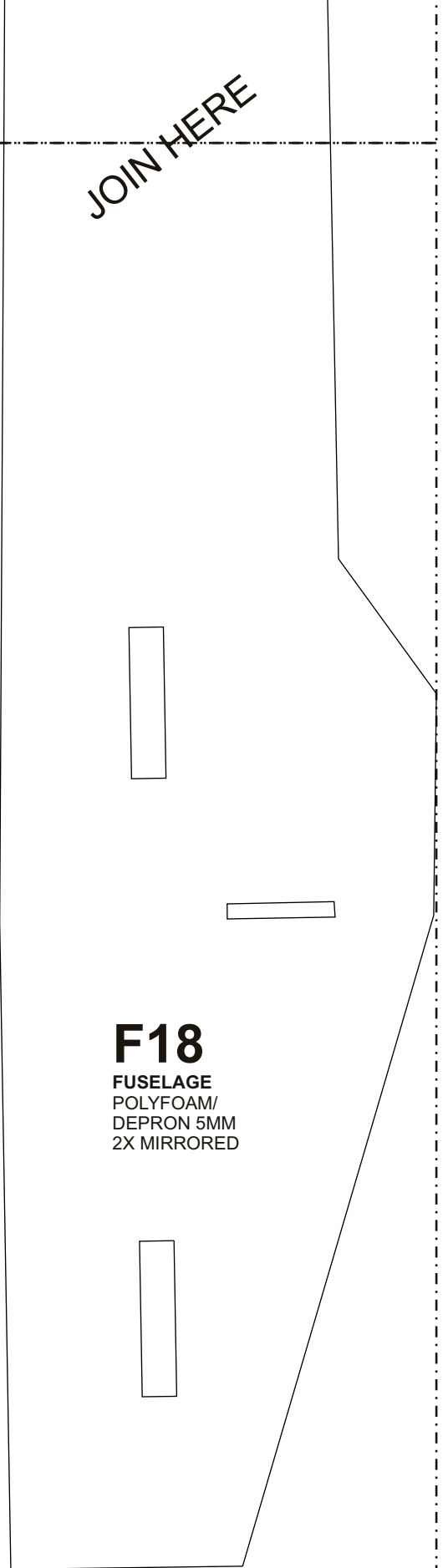

F29

FUSELAGE
POLYFOAM/
DEPRON 5MM
2X MIRRORED

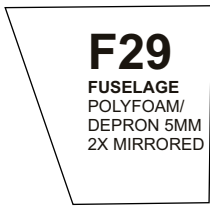

JOIN HERE

F25

FUSELAGE
POLYFOAM/
DEPRON 5MM

JOIN HERE

JOIN HERE

F25

F42

FUSELAGE
POLYFOAM/
DEPRON 5MM
6X

F26

FUSELAGE
POLYFOAM/
DEPRON 5MM

JOIN HERE

JOIN HERE

F25

JOIN HERE

F34

FUSELAGE FORMER
POLYFOAM/
DEPRON 5MM
2X MIRRORED

JOIN HERE

F26

JOIN HERE

F25

F34

F30

FUSELAGE
POLYFOAM/
DEPRON 5MM
2X MIRRORED

F31

FUSELAGE
POLYFOAM/
DEPRON 5MM
2X MIRRORED

JOIN HERE

JOIN HERE

F30
FUSELAGE
POLYFOAM/
DEPRON 5MM
2X MIRRORED

JOIN HERE

F30

F31

JOIN HERE

F39
FUSELAGE
POLYFOAM/
DEPRON 5MM
2X MIRRORED

JOIN HERE

JOIN HERE

JOIN HERE

F39

JOIN HERE

W7
2X

F35

FUSELAGE
POLYFOAM/
DEPRON 5MM

JOIN HERE

JOIN HERE

F35

JOIN HERE

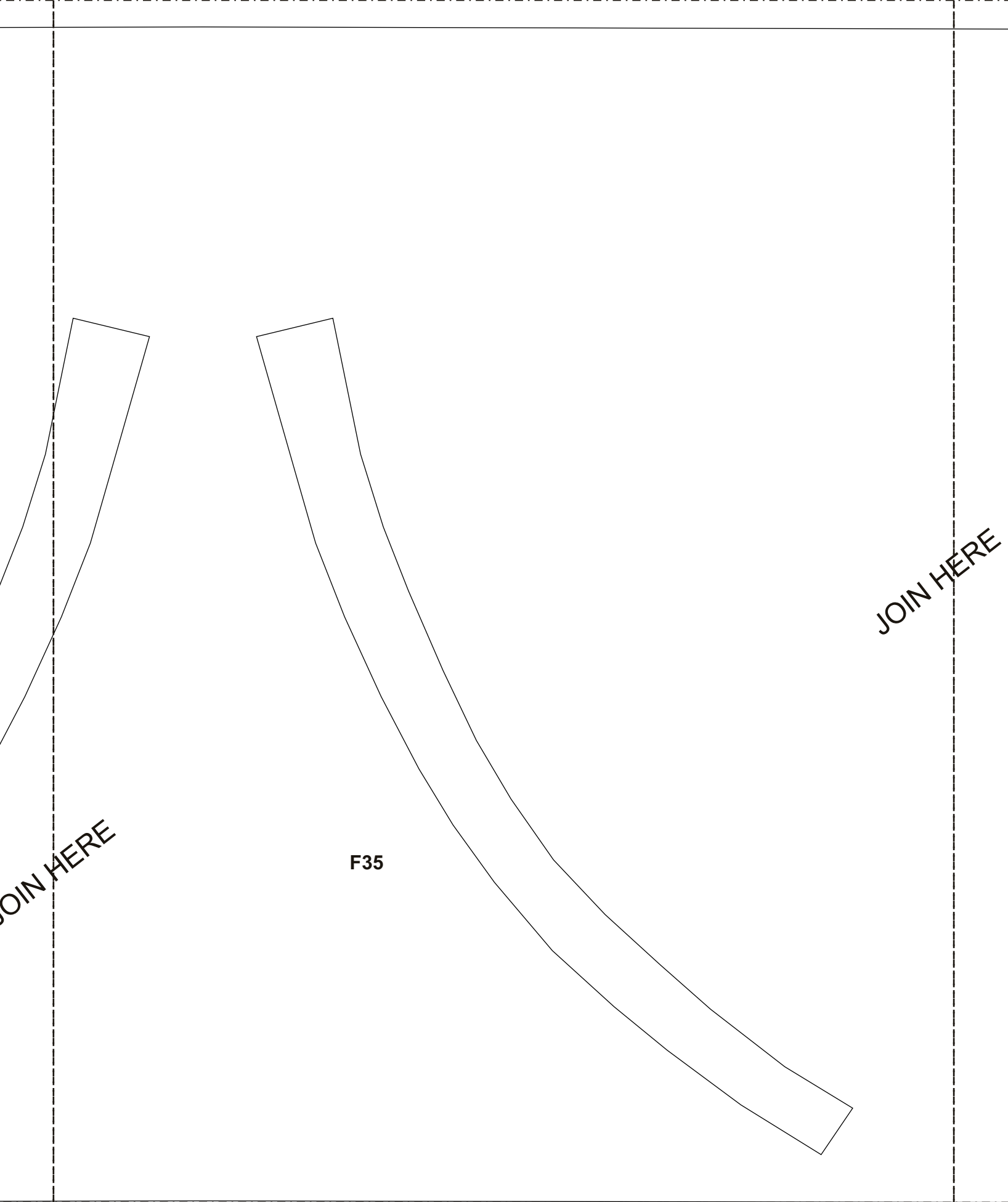

F35

JOIN HERE

F66

AIR INTAKE
POLYFOAM/
DEPRON 5MM
2X MIRRORED

JOIN HERE

JOIN HERE

F66

W1

WING BASE
POLYFOAM/
DEPRON 5MM
2X MIRRORED

JOIN HERE

JOIN HERE

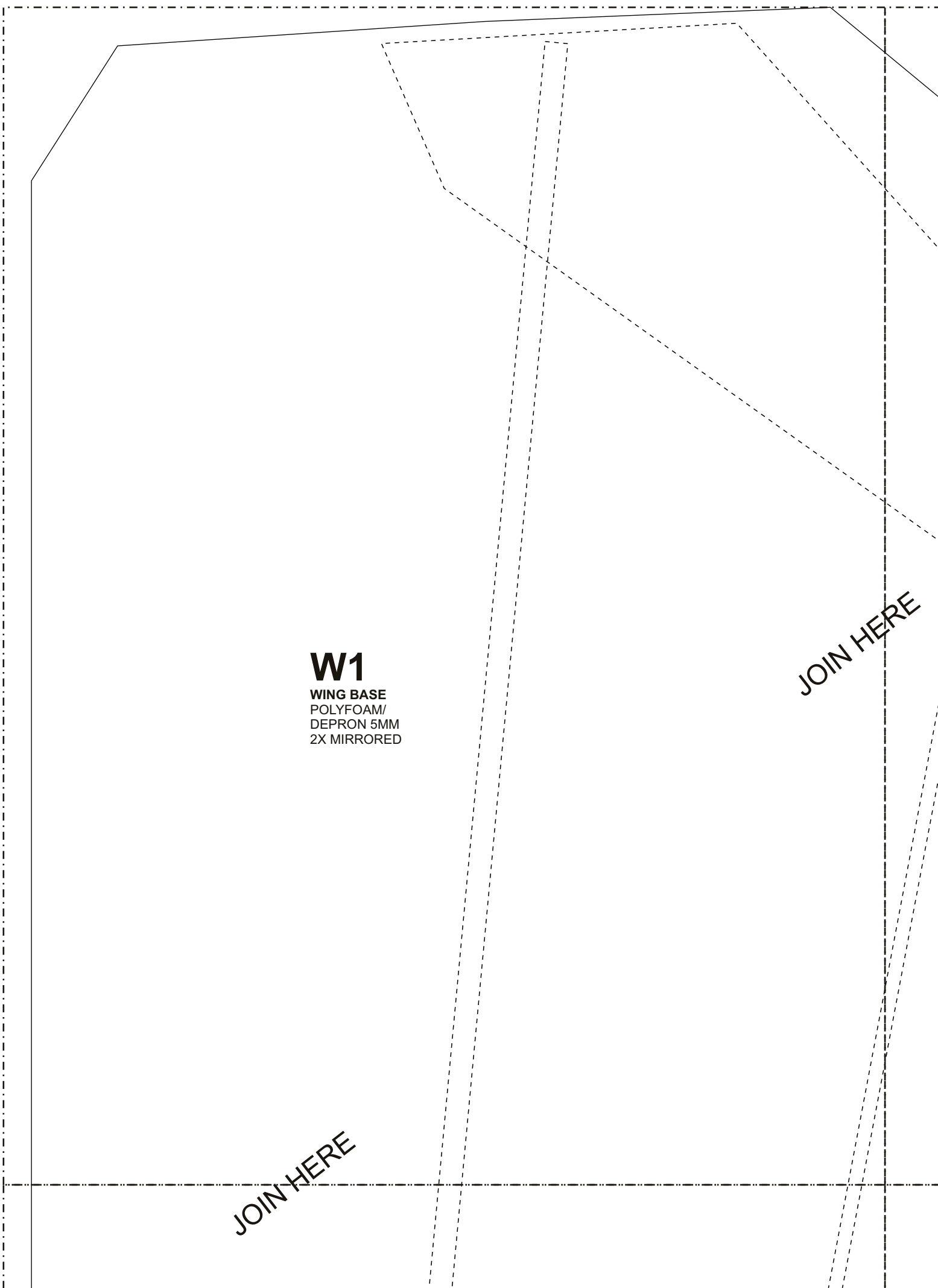

F47
FUSELAGE
POLYFOAM/
DEPRON 5MM
2X MIRRORED

JOIN HERE

W1

F46

JOIN HERE

JOIN HERE

JOIN HERE

W1

JOIN HERE

JOIN HERE

JOIN HERE

W1

F46

FUSELAGE
POLYFOAM/
DEPRON 5MM
2X MIRRORED

JOIN HERE

W1

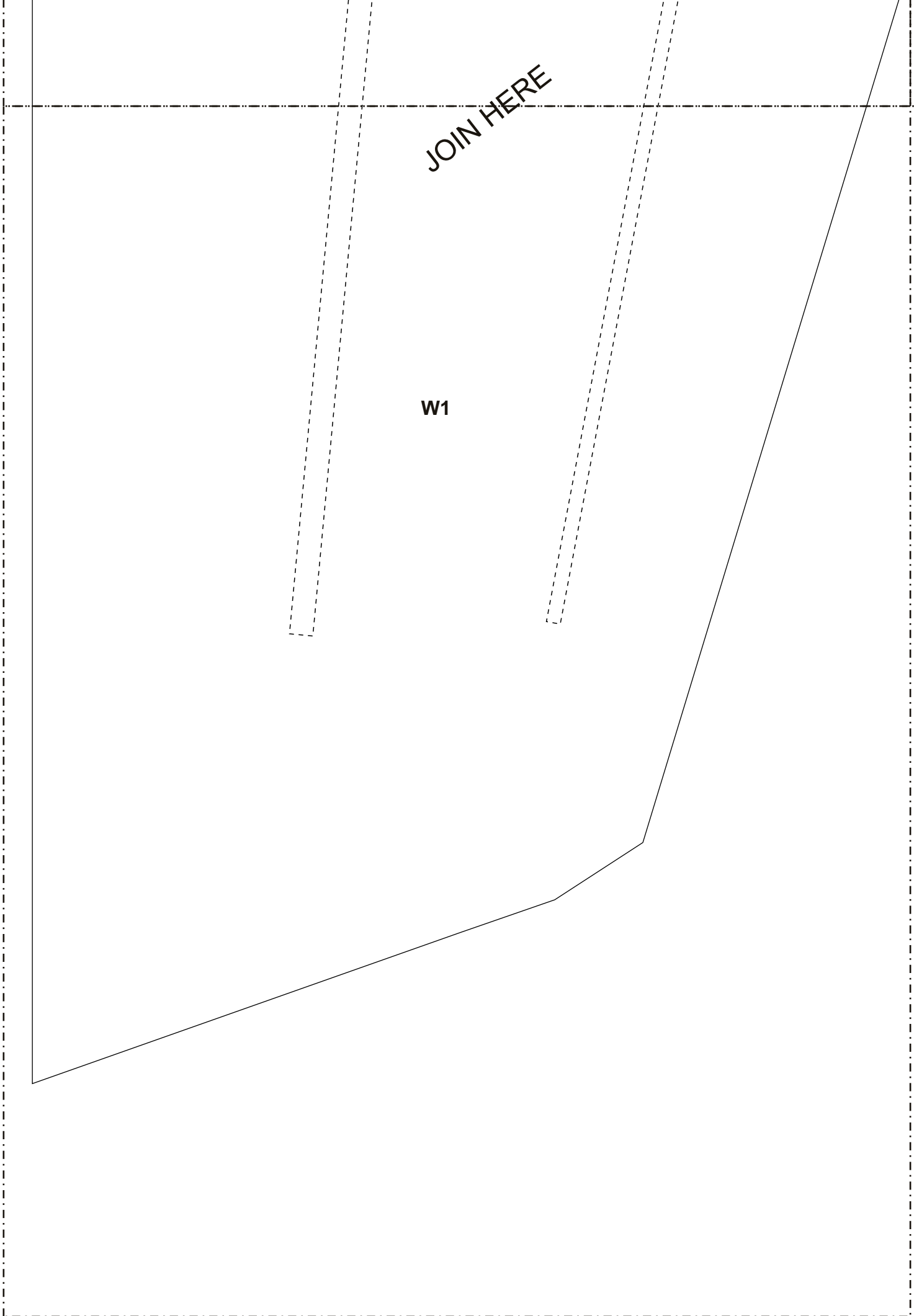



W8

WING TOP
POLYFOAM/
DEPRON 5MM
2X MIRRORED

JOIN HERE

JOIN HERE

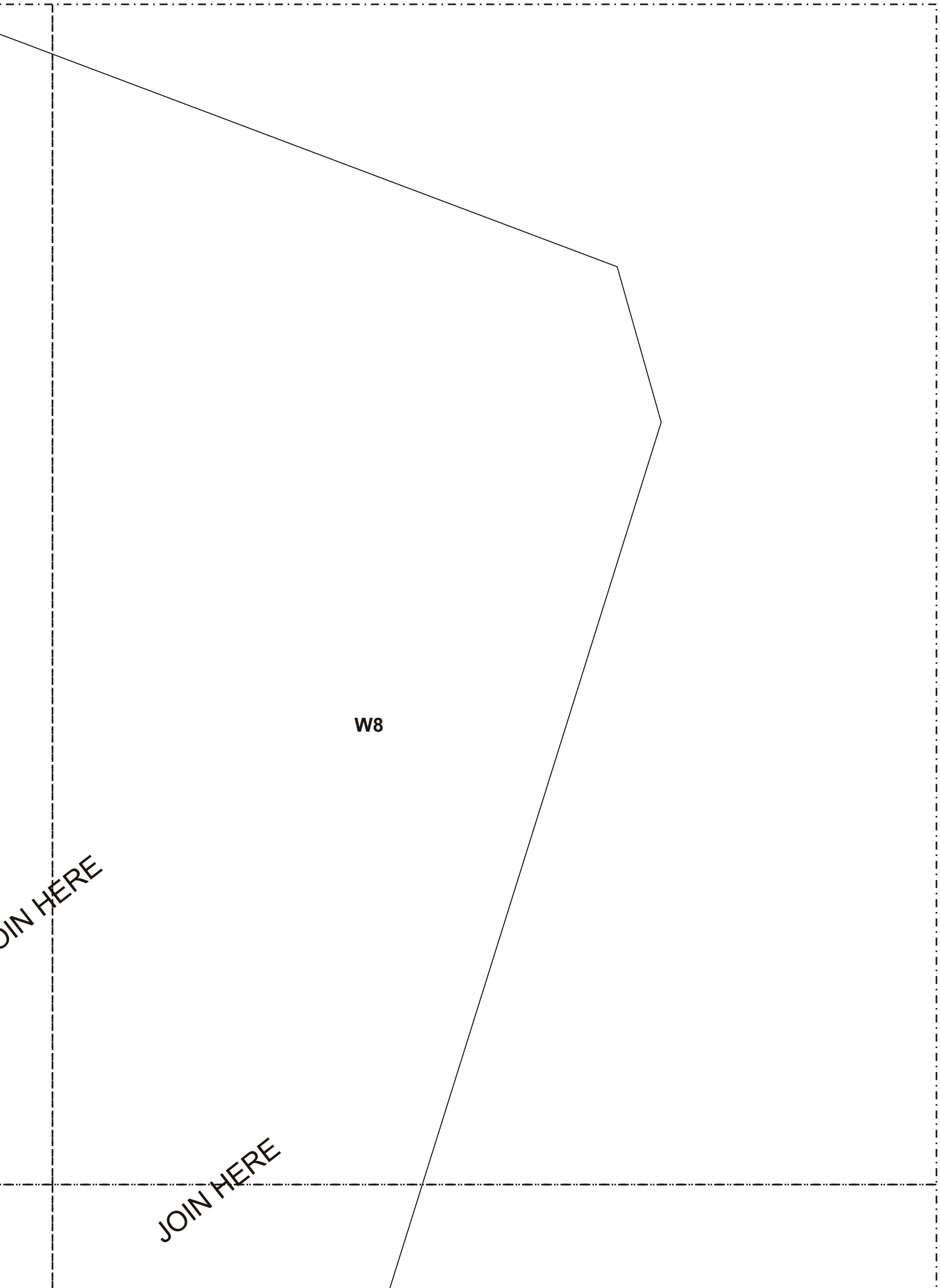

W8

JOIN HERE

JOIN HERE

JOIN HERE

JOIN HERE

W8

JOIN HERE

JOIN HERE

W8

JOIN HERE

F45

FUSELAGE
POLYFOAM/
DEPRON 5MM
2X MIRRORED

F48

FUSELAGE
POLYFOAM/
DEPRON 5MM
2X MIRRORED

JOIN HERE

JOIN HERE

JOIN HERE

W8

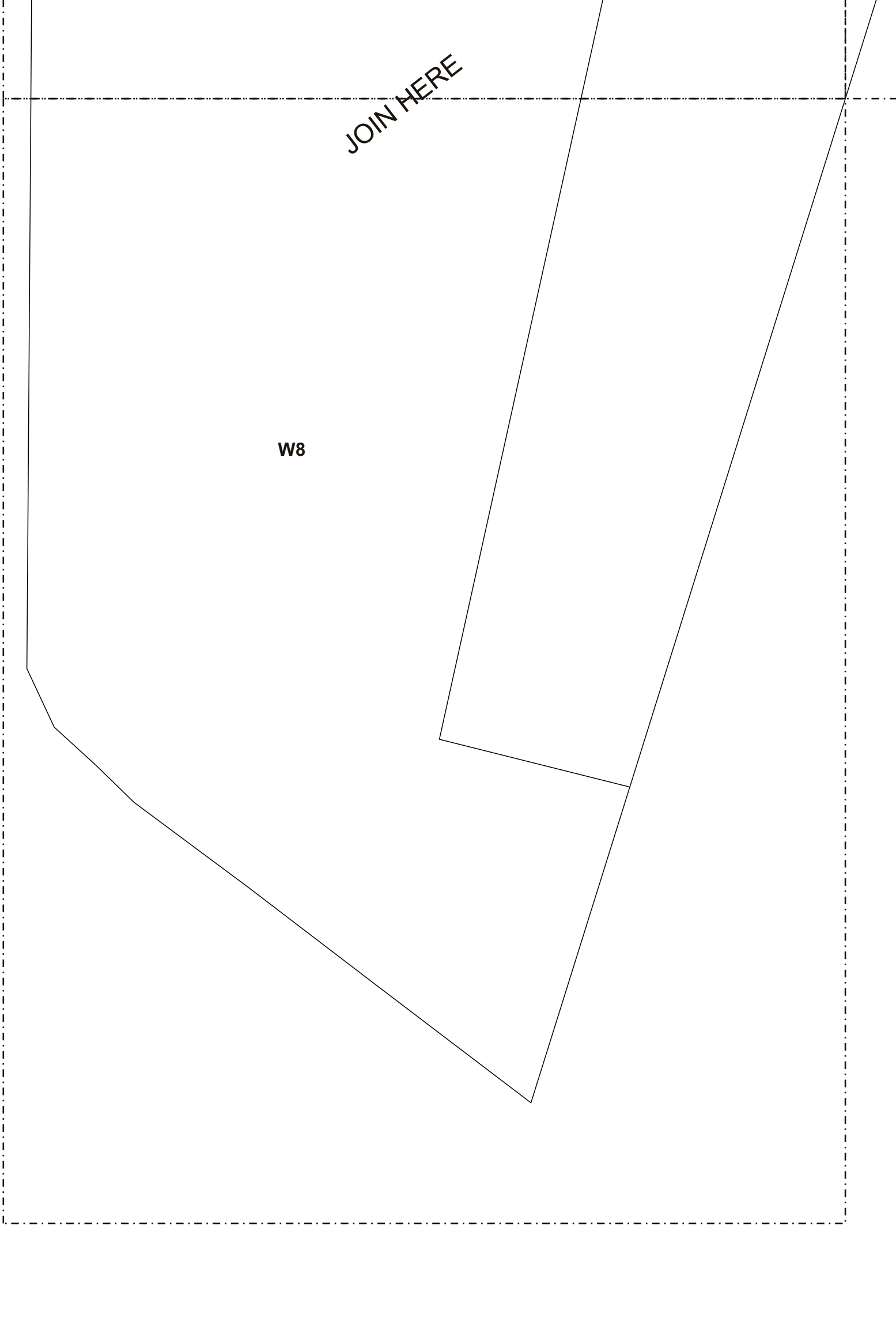

JOIN HERE

JOIN HERE

F48

F45

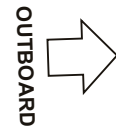

FRONT



F43

FUSELAGE
POLYFOAM/
DEPRON 5MM

JOIN HERE

JOIN HERE

F43

F49

FUSELAGE
POLYFOAM/
DEPRON 5MM

JOIN HERE

JOIN HERE

F49

F50

FUSELAGE
POLYFOAM/
DEPRON 5MM
2X MIRRORED

JOIN HERE

F51

FUSELAGE
POLYFOAM/
DEPRON 5MM
2X MIRRORED

JOIN HERE

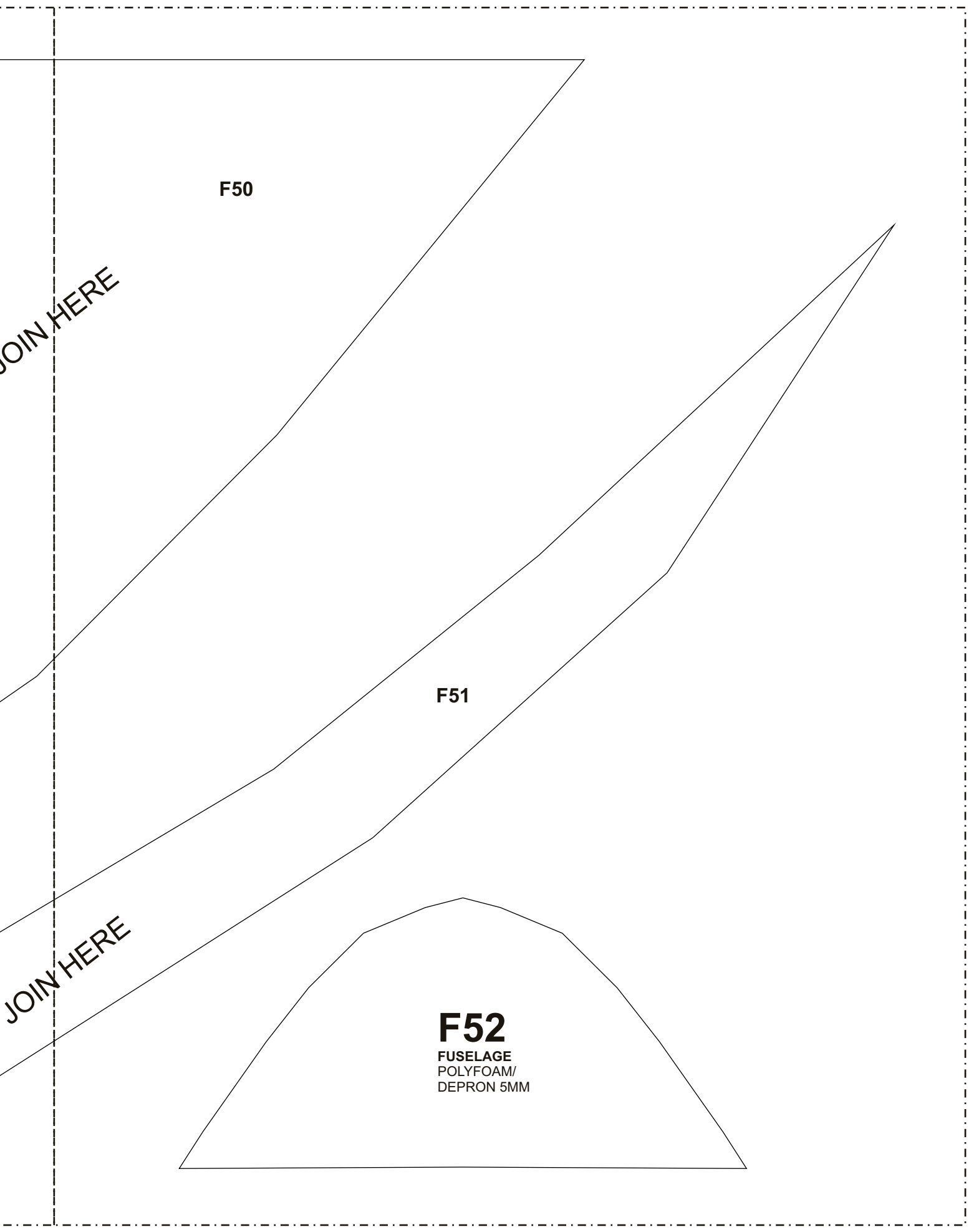

F50

JOIN HERE

F51

JOIN HERE

F52

FUSELAGE
POLYFOAM/
DEPRON 5MM



F53
FUSELAGE
POLYFOAM/
DEPRON 5MM

JOIN HERE

JOIN HERE

F53

JOIN HERE

JOIN HERE

S1

ELEVATOR
POLYFOAM/
DEPRON 5MM
4X MIRRORED

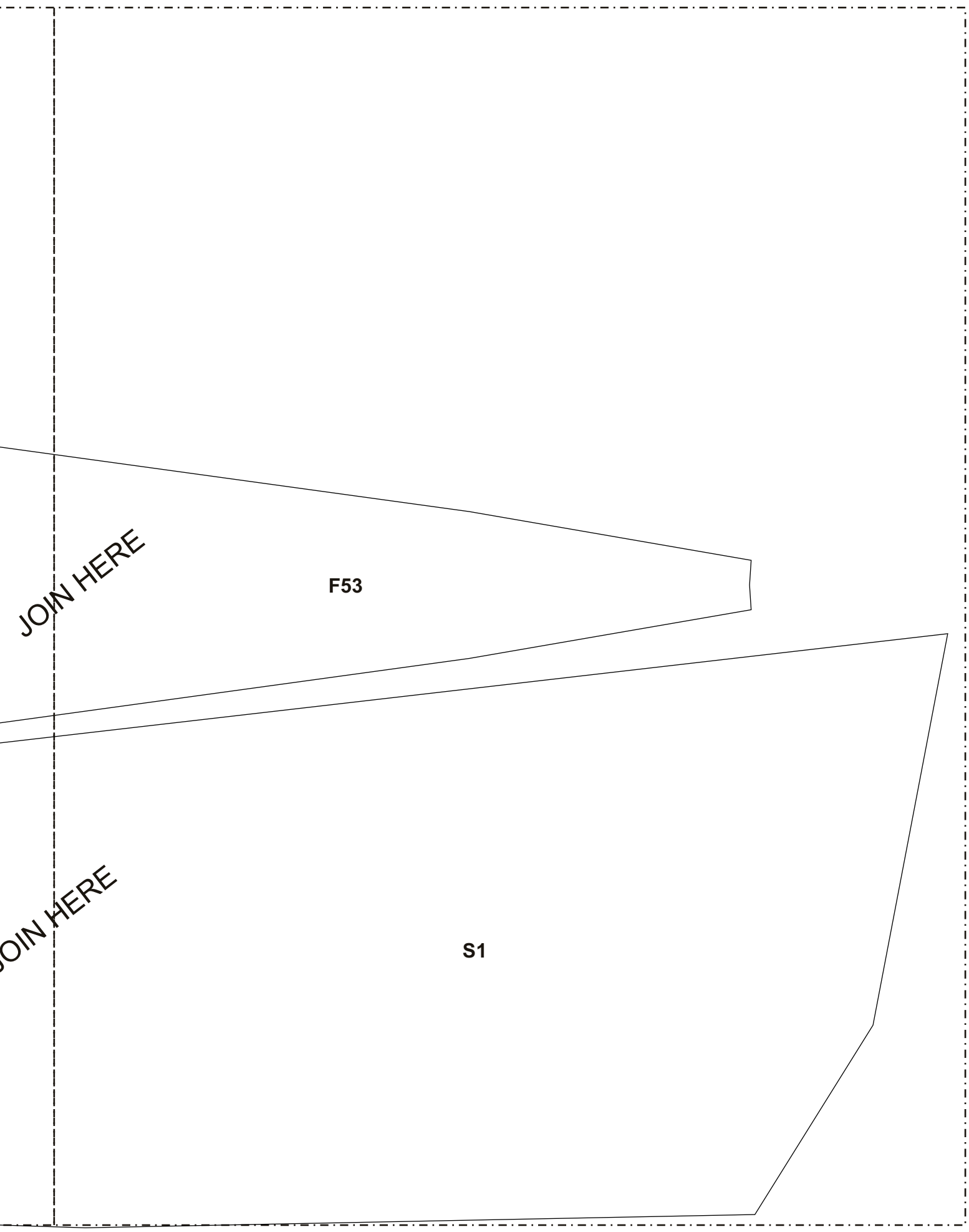

JOIN HERE

F53

JOIN HERE

S1



S1

**HOR-STAB
POLYFOAM/
DEPRON 5MM
4X MIRRORED**

JOIN HERE

JOIN HERE

S1

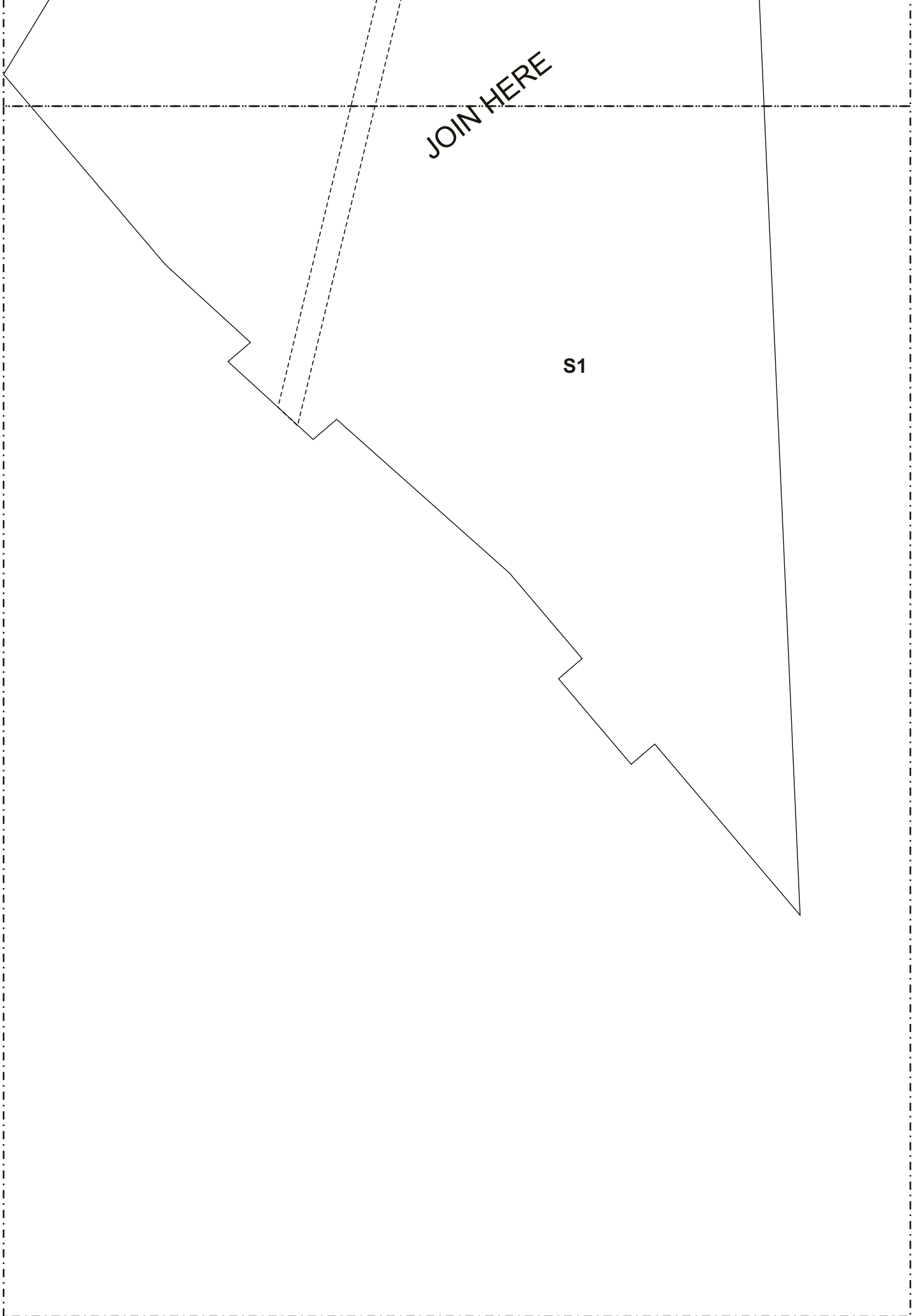

F54
EXHAUST NOZZLE
POLYFOAM/
DEPRON 5MM
2X MIRRORED

JOIN HERE

F59
FUSELAGE
POLYFOAM/
DEPRON 5MM
2X MIRRORED

JOIN HERE

JOIN HERE

JOIN HERE

F54

F59

F63

AIR INTAKE
POLYFOAM/
DEPRON 5MM
2X MIRRORED

F55

EXHAUST NOZZLE
POLYFOAM/
DEPRON 5MM
2X MIRRORED

JOIN HERE

JOIN HERE

JOIN HERE

JOIN HERE

F63

F55



F56

TAIL SECTION
POLYFOAM/
DEPRON 5MM

F57 2X



F58

**TAIL SECTION
POLYFOAM/
DEPRON 5MM**

F60

FUSELAGE
POLYFOAM/
DEPRON 5MM

JOIN HERE

F69

JOIN HERE

JOIN HERE

F69

JOIN HERE

F60

FRONT



F69

AIR INTAKE
POLYFOAM/
DEPRON 5MM
2X MIRRORED

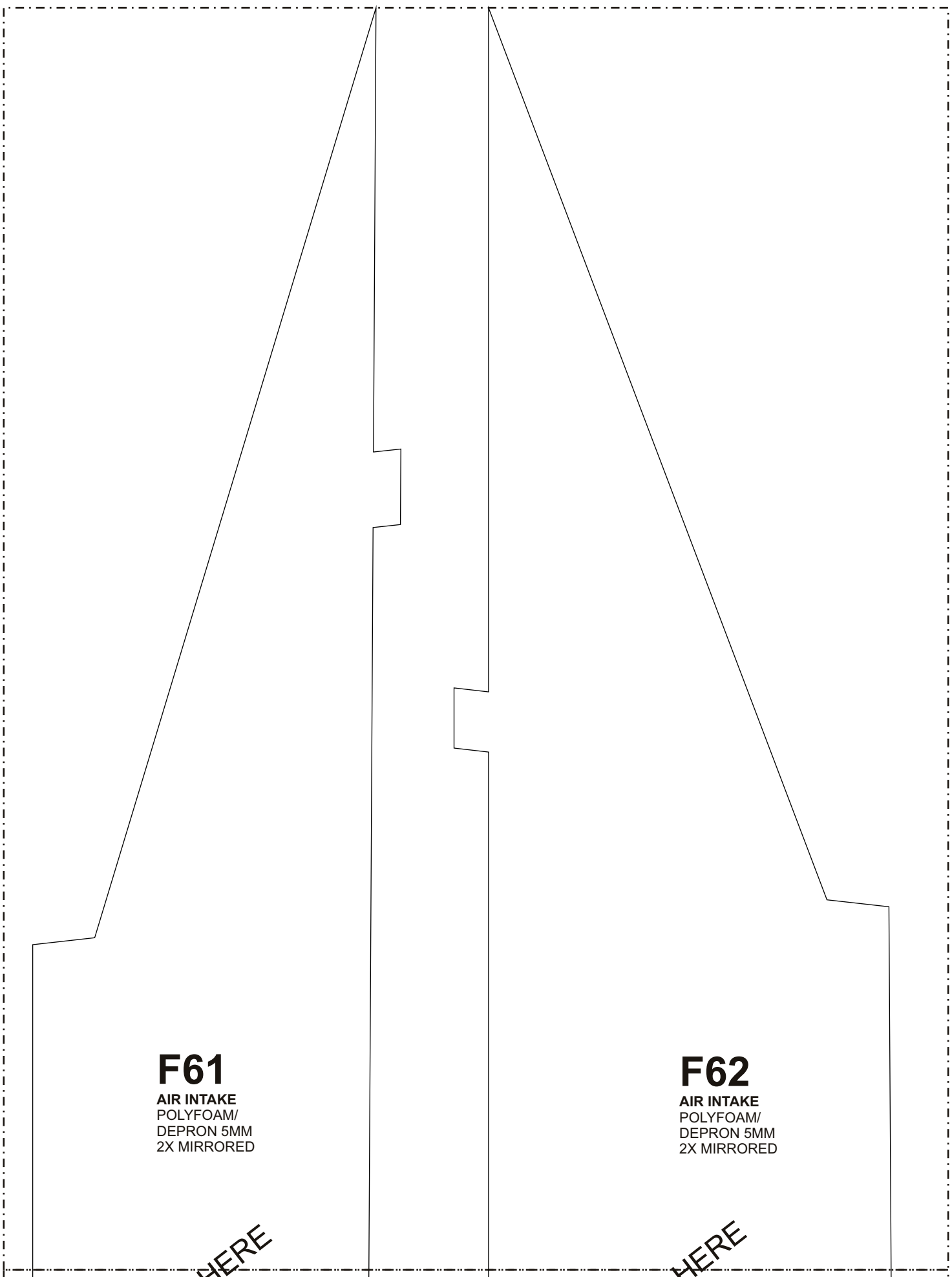

F61

AIR INTAKE
POLYFOAM/
DEPRON 5MM
2X MIRRORED

JOIN HERE

F62

AIR INTAKE
POLYFOAM/
DEPRON 5MM
2X MIRRORED

JOIN HERE

JOIN HERE

JOIN HERE

F61

F62

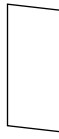

F64

AIR INTAKE
POLYFOAM/
DEPRON 5MM
2X MIRRORED

F65

AIR INTAKE
POLYFOAM/
DEPRON 5MM
2X MIRRORED

JOIN HERE

JOIN HERE

JOIN HERE

JOIN HERE

F64

F65

F67

AIR INTAKE
POLYFOAM/
DEPRON 5MM
2X MIRRORED

F68

AIR INTAKE
POLYFOAM/
DEPRON 5MM
2X MIRRORED

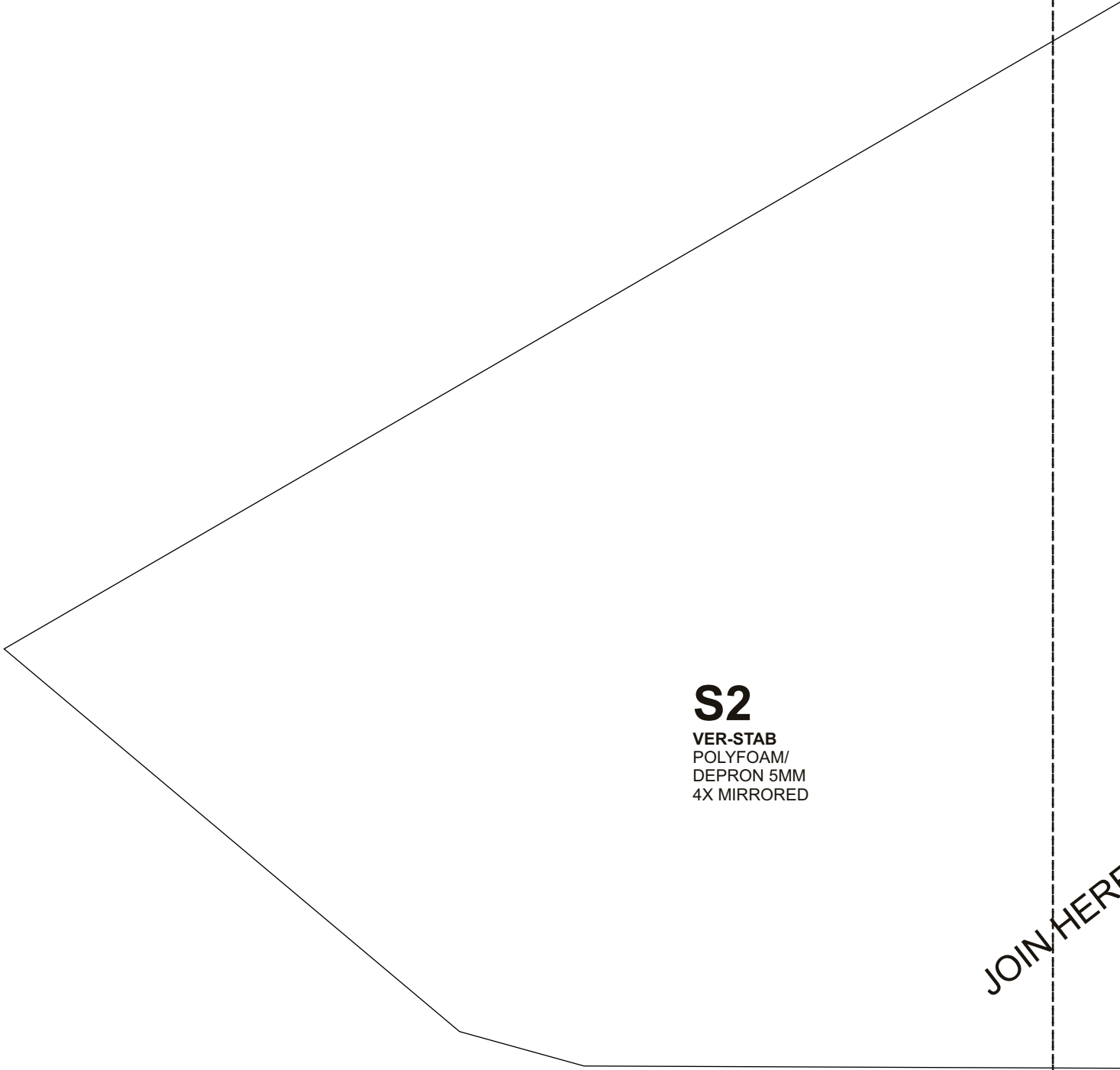

S2

VER-STAB
POLYFOAM/
DEPRON 5MM
4X MIRRORED

JOIN HERE

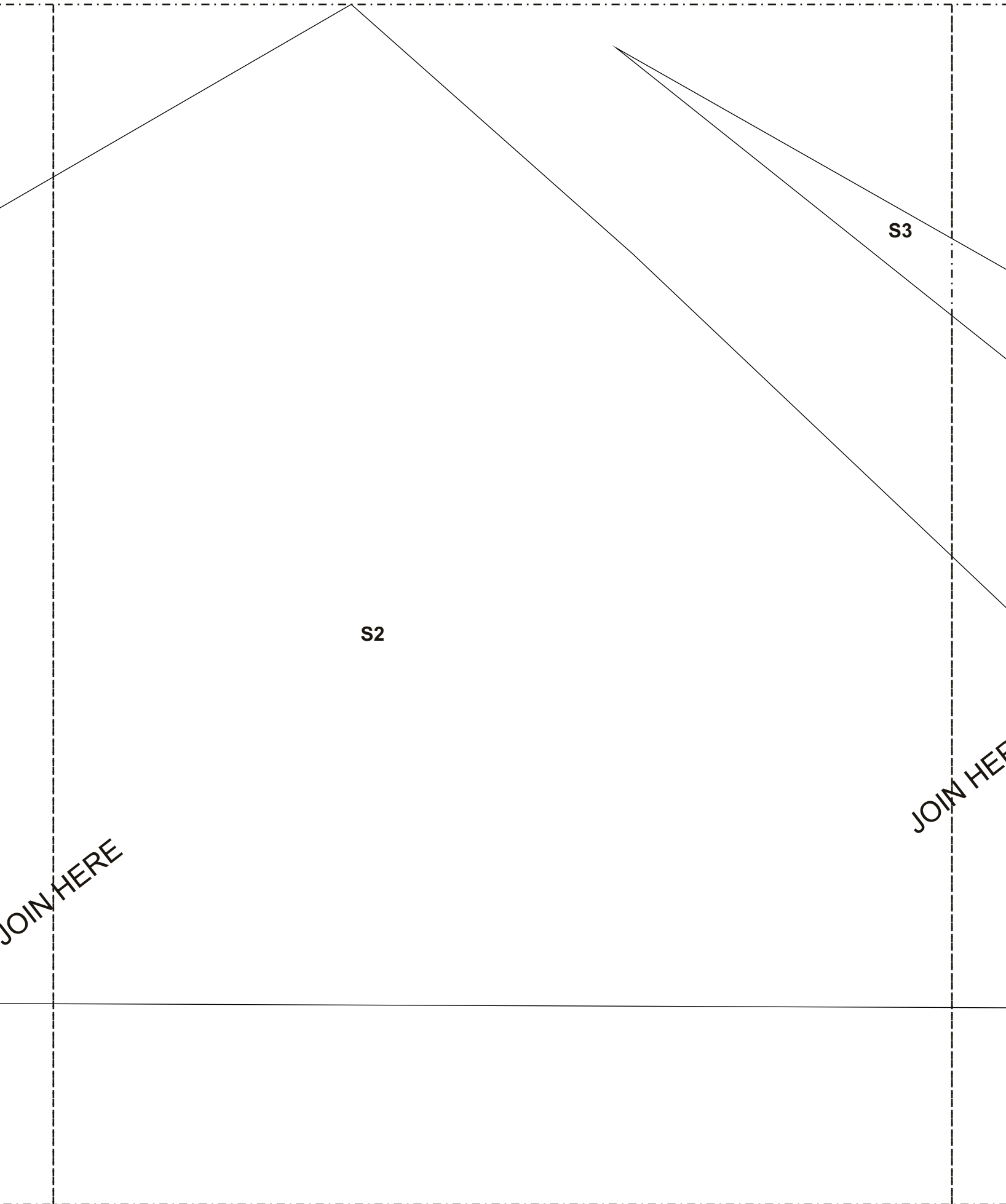

S2

S3

JOIN HERE

JOIN HERE

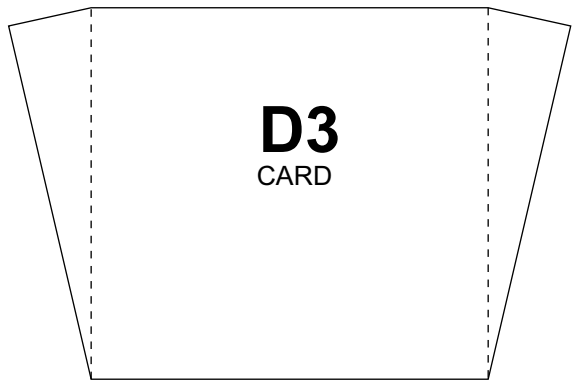
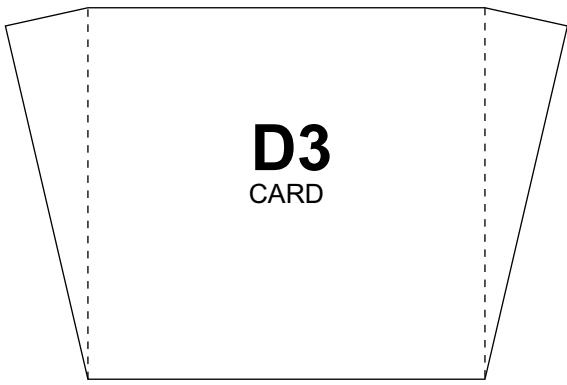

S3
VER-STAB
POLYFOAM/
DEPRON 5MM
4X MIRRORED

A large, irregular pattern piece with a jagged, sawtooth-like top edge and a long, narrow tail extending to the right. The text "S3 VER-STAB POLYFOAM/ DEPRON 5MM 4X MIRRORED" is located in the upper-middle section of the piece.

S2

A large, irregular pattern piece with a jagged, sawtooth-like top edge and a long, narrow tail extending to the right. The text "S2" is located in the lower-left section of the piece.

JOIN HERE

A diagonal line runs from the top-left towards the bottom-right, intersecting the pattern pieces. The text "JOIN HERE" is written along this line, indicating where the pieces should be joined.

3

A small number "3" is located on the left side of the page, near the top edge.



C10
CANOPY MOLD
POLYFOAM 5MM
18X



D10
LG DOOR
POLYFOAM
3MM



C11

CANOPY MOLD
POLYFOAM 5MM
18X

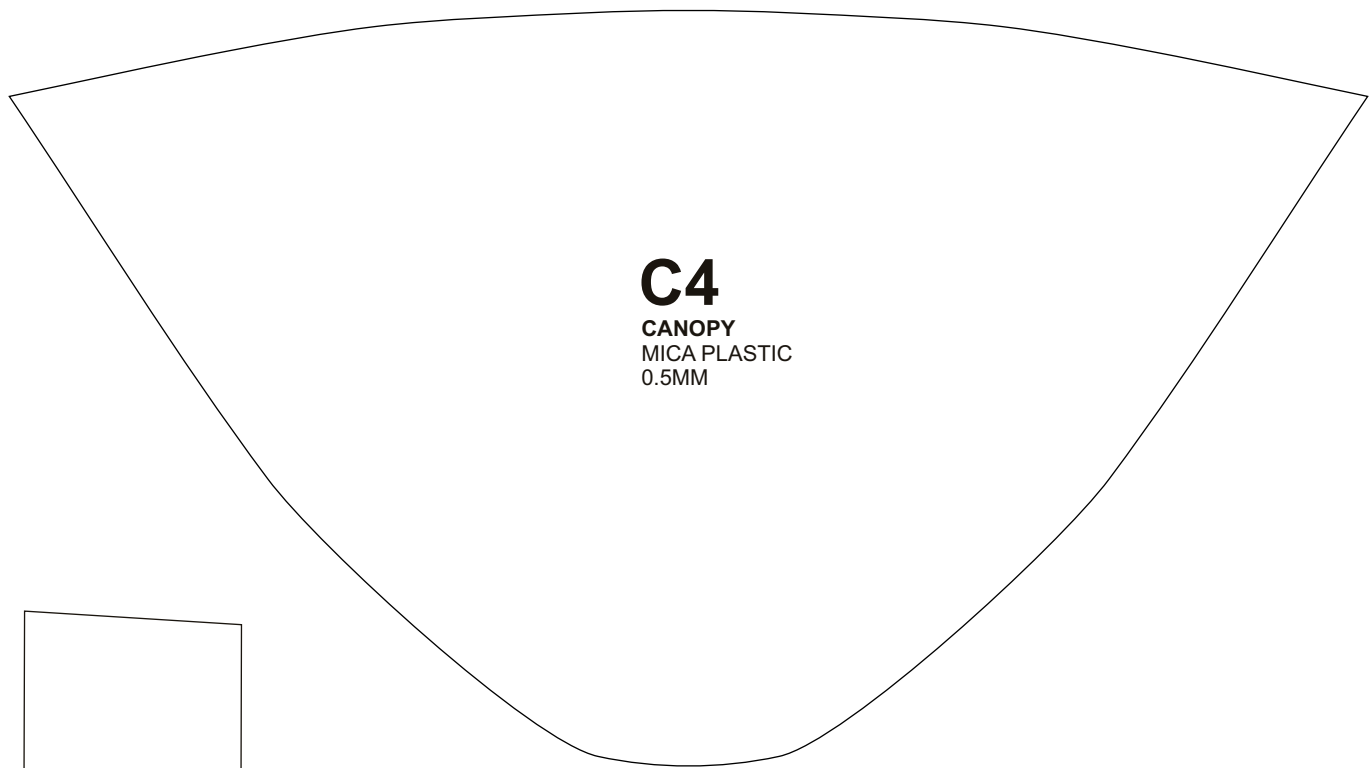

C4
CANOPY
MICA PLASTIC
0.5MM



D8
LG DOOR
POLYFOAM 3MM
2X



D9
LG DOOR
POLYFOAM
3MM
2X

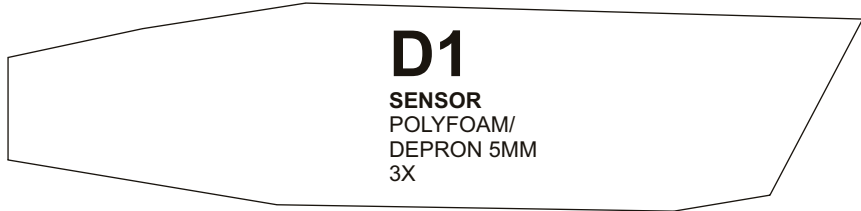

D1
SENSOR
POLYFOAM/
DEPRON 5MM
3X

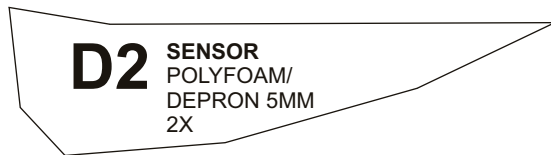

D2 SENSOR
POLYFOAM/
DEPRON 5MM
2X

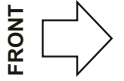
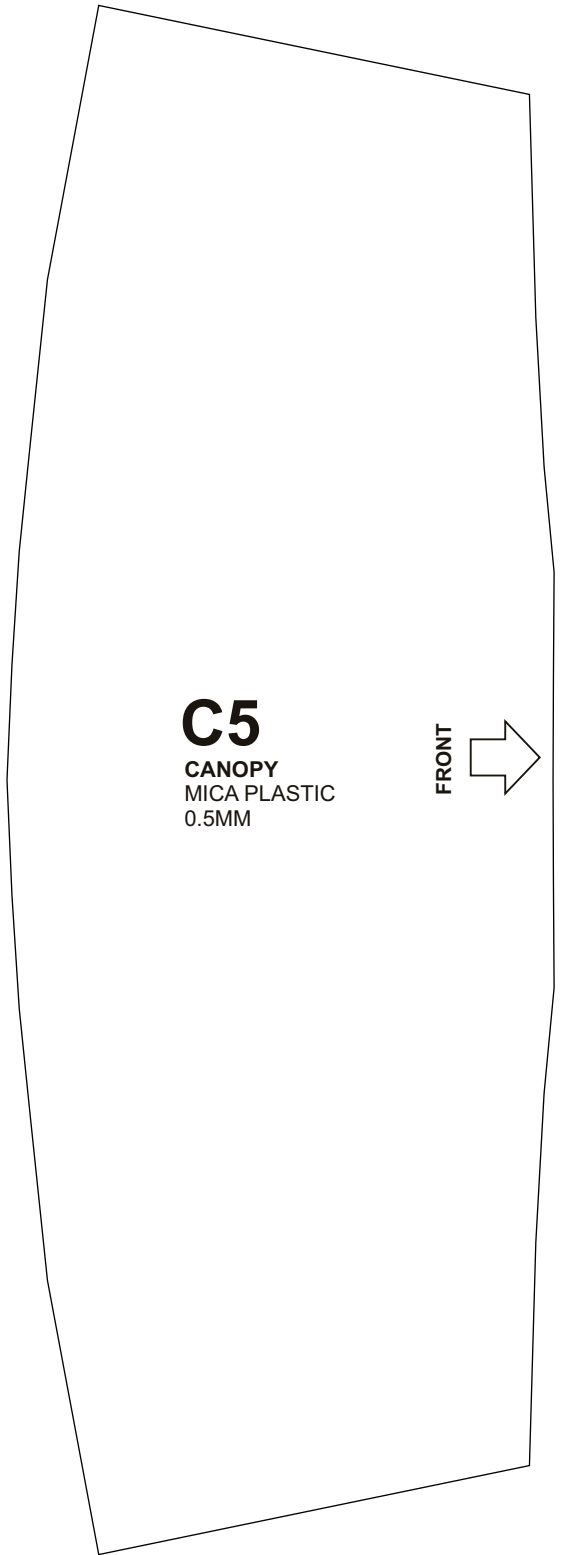
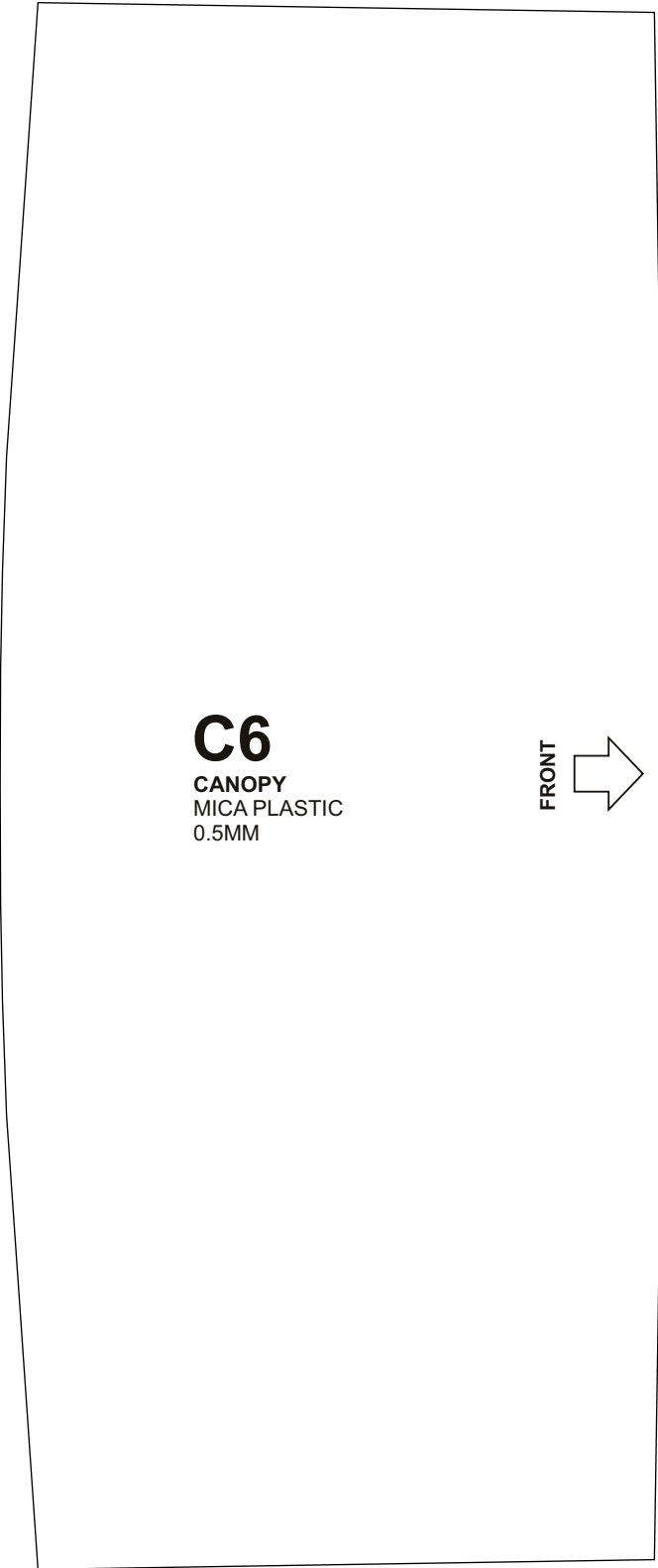

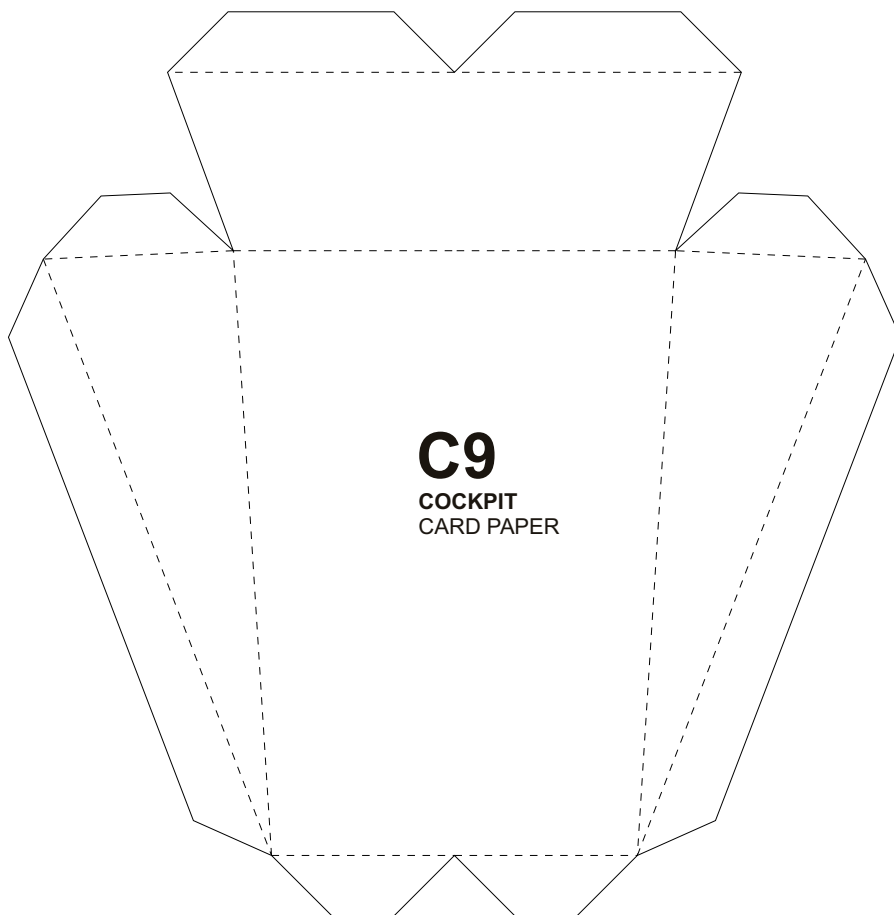
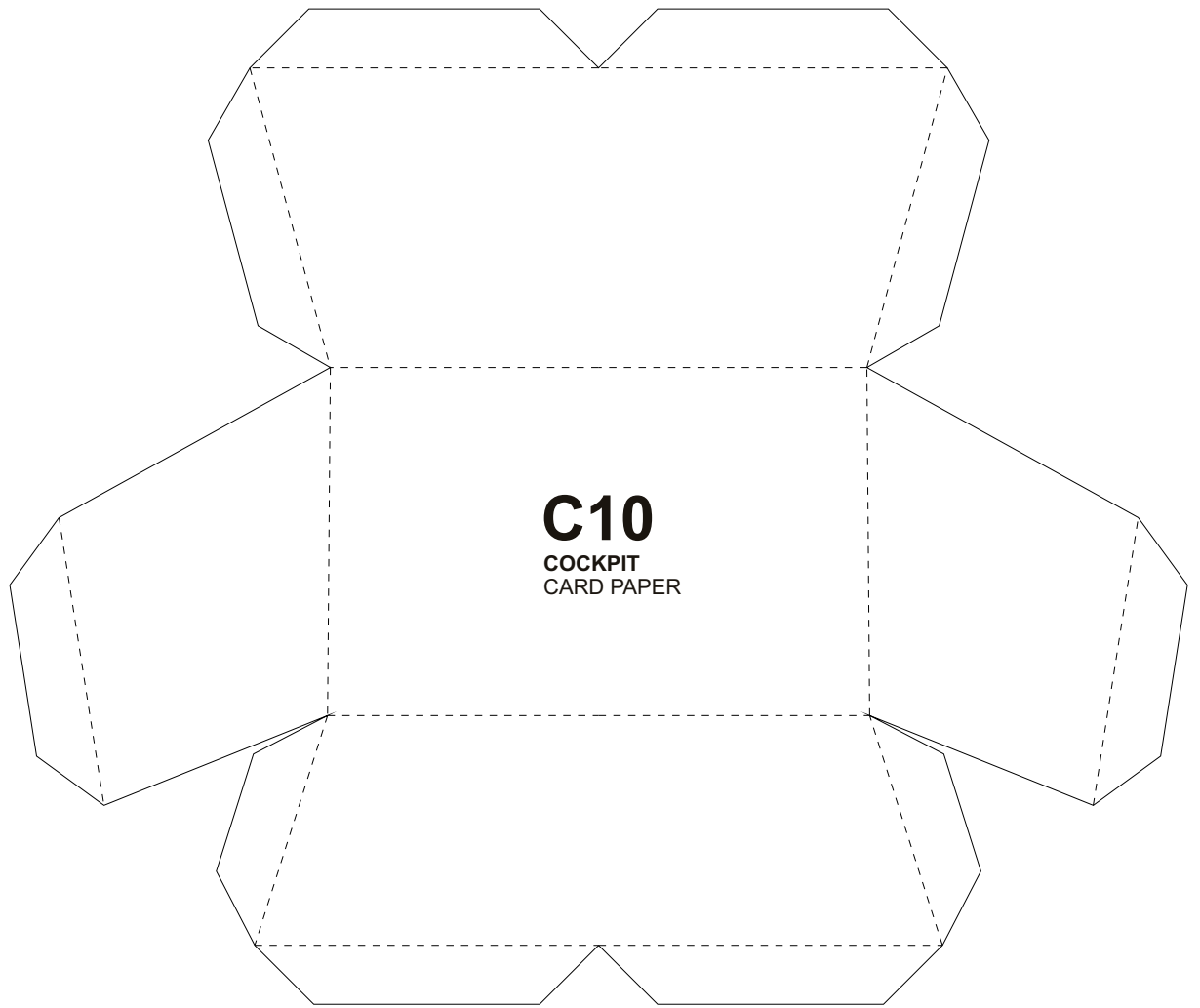

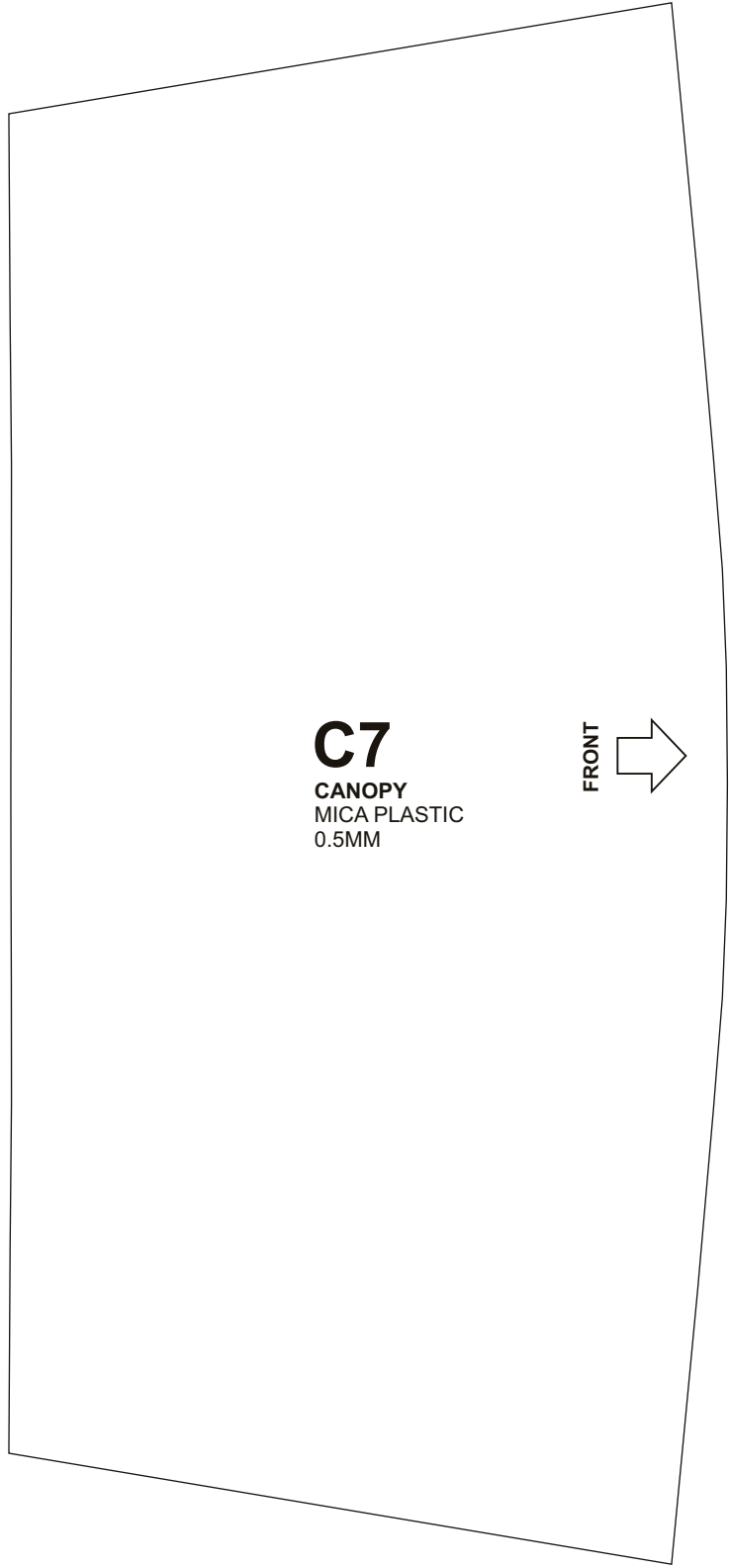

C7
CANOPY
MICA PLASTIC
0.5MM



C8
CANOPY
MICA PLASTIC
0.5MM

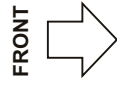

D5
PYLONS
PLYWOOD 5MM
2X

D4
PYLONS
PLYWOOD 5MM
2X

JOIN HERE

JOIN HERE

JOIN HERE

D5

JOIN HERE

D4

D6

PYLONS
PLYWOOD 5MM
2X

D6

PYLONS
PLYWOOD
5MM
2X

Fixed landing gear size 1:1

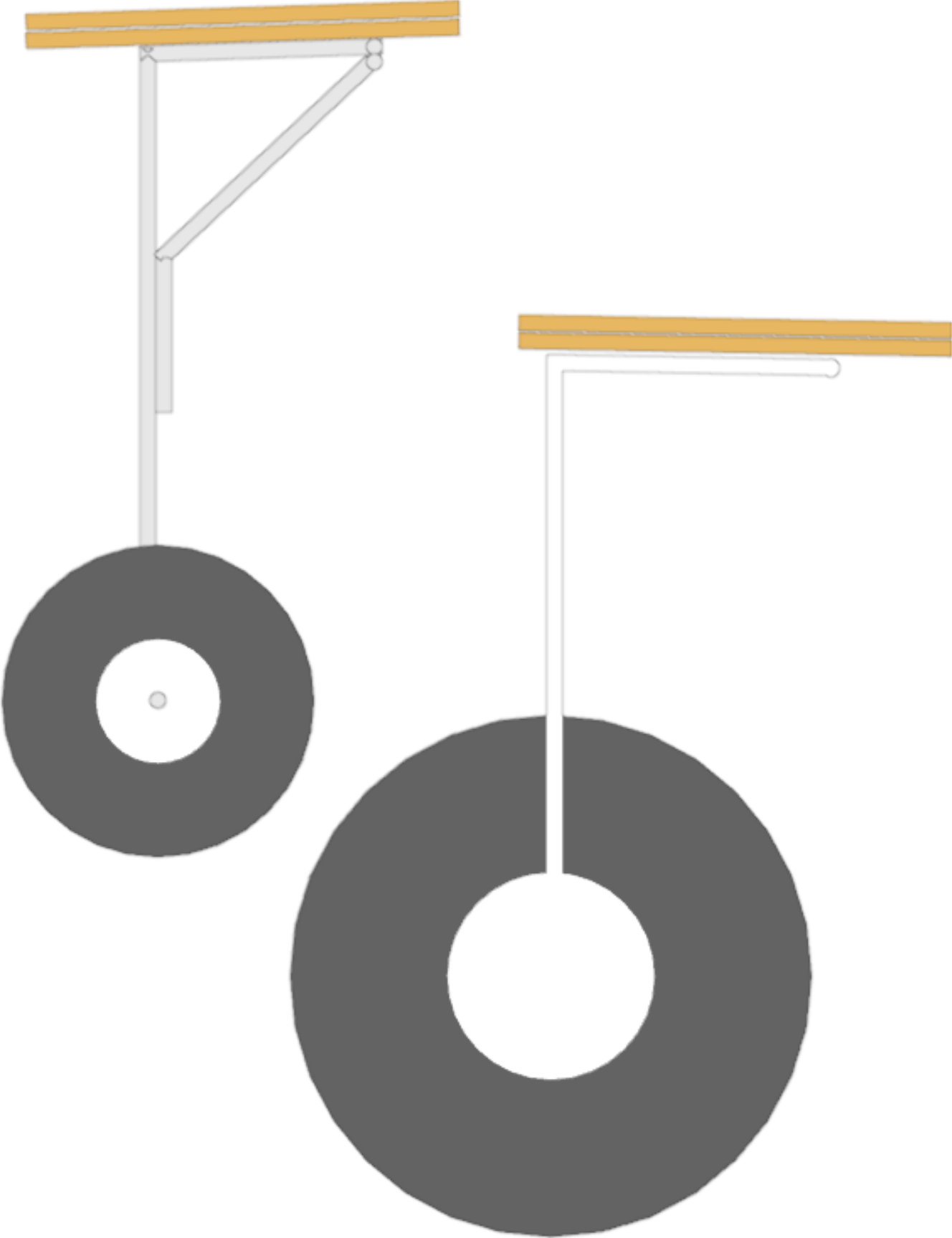

CG (Center of Gravity)

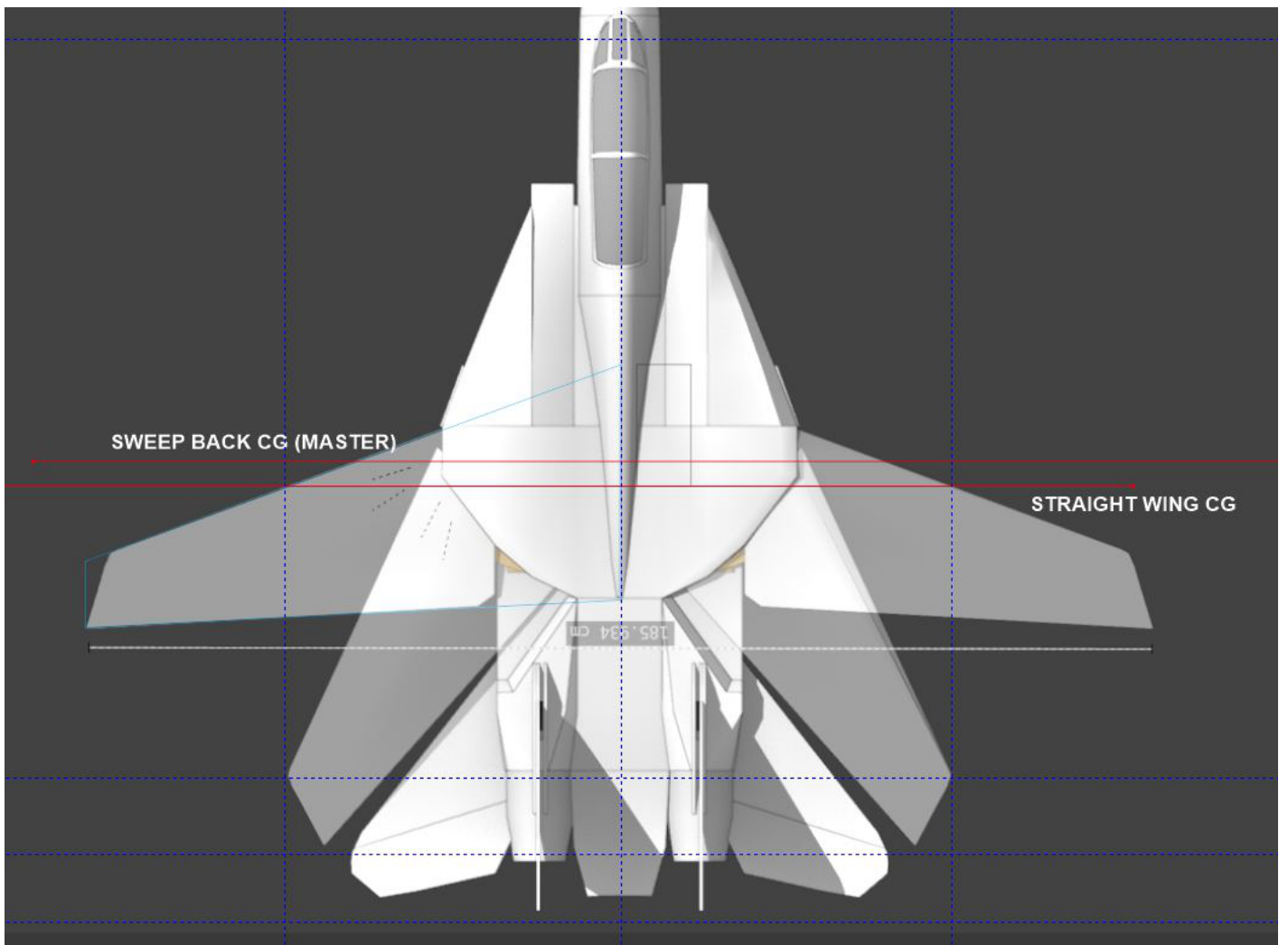

3MM PLYWOOD PARTS

M1

CHEAT HOLES
PLYWOOD 3MM
4X

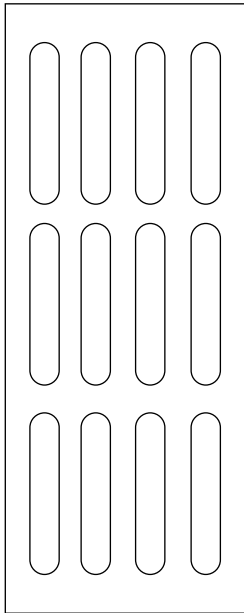
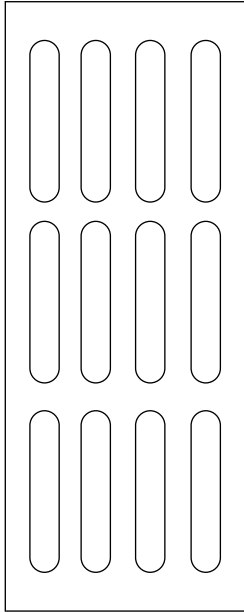

M2

CHEAT HOLES
PLYWOOD 3MM
2X

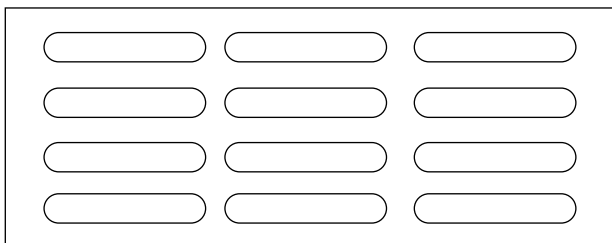
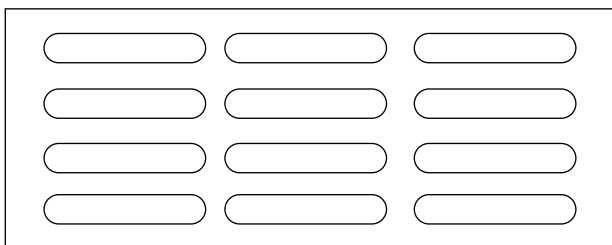
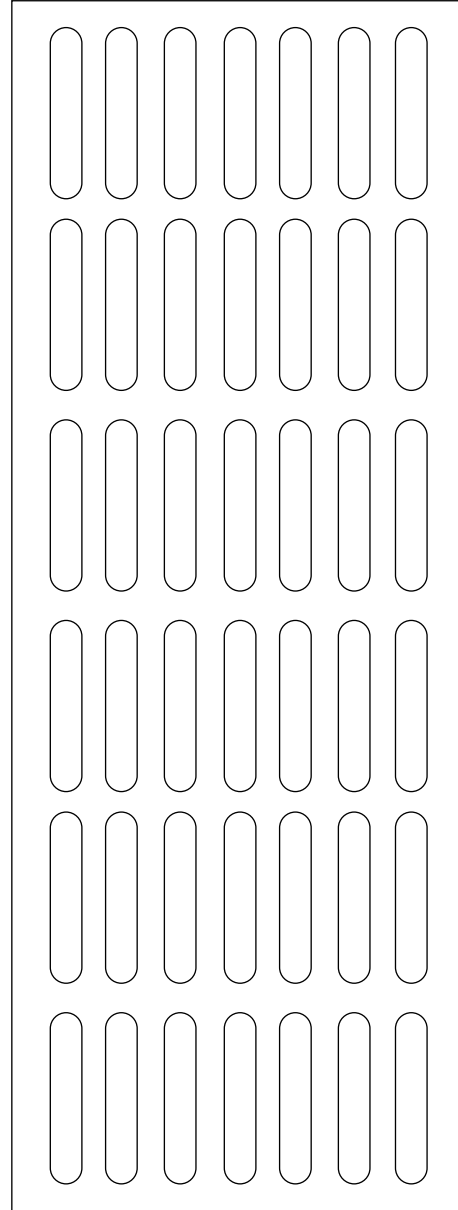
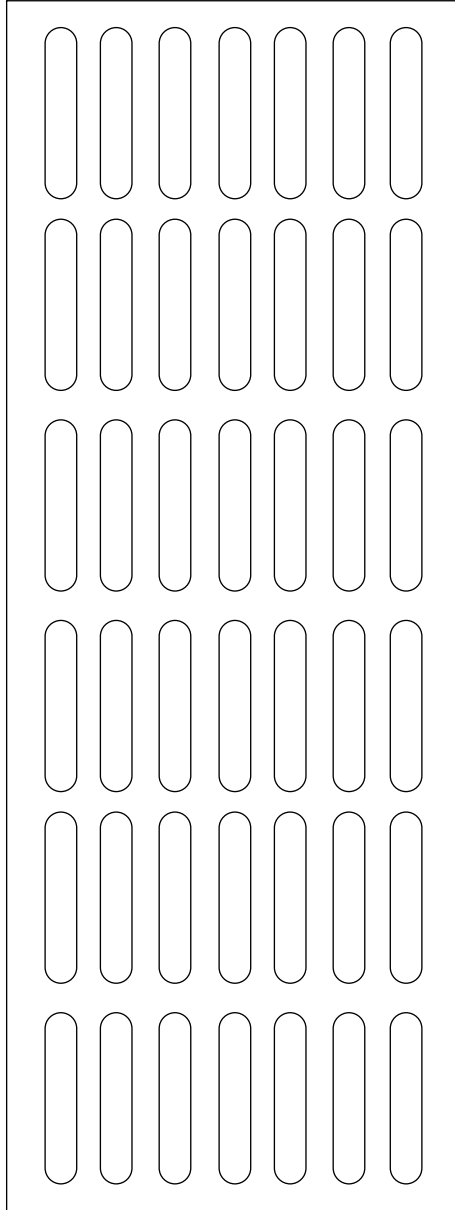

G1

LG BASE
PLYWOOD 3MM



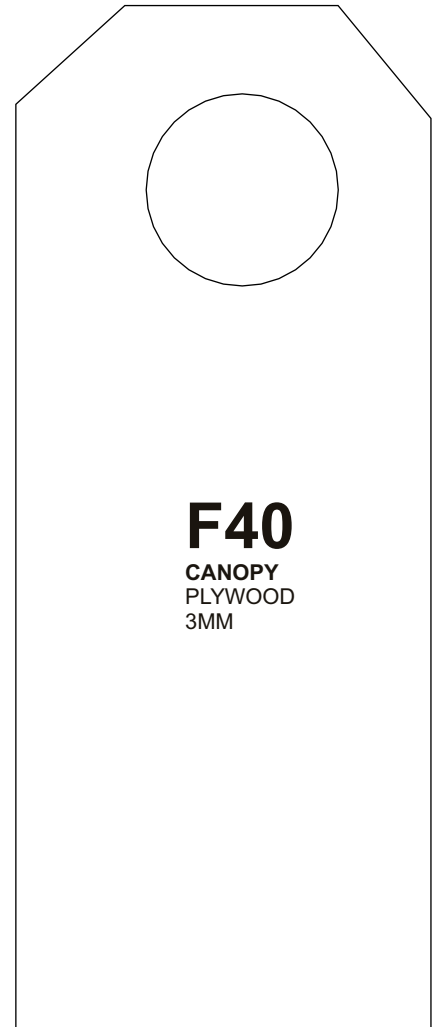
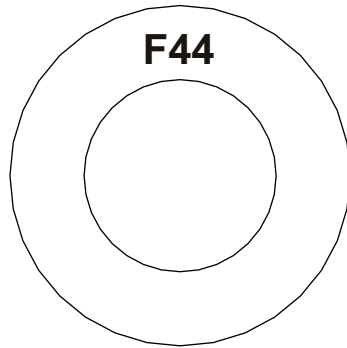
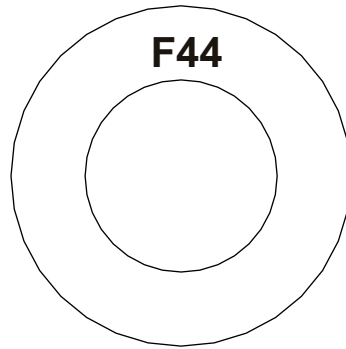
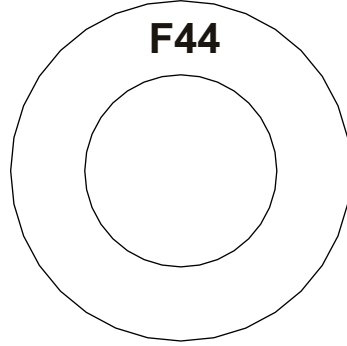
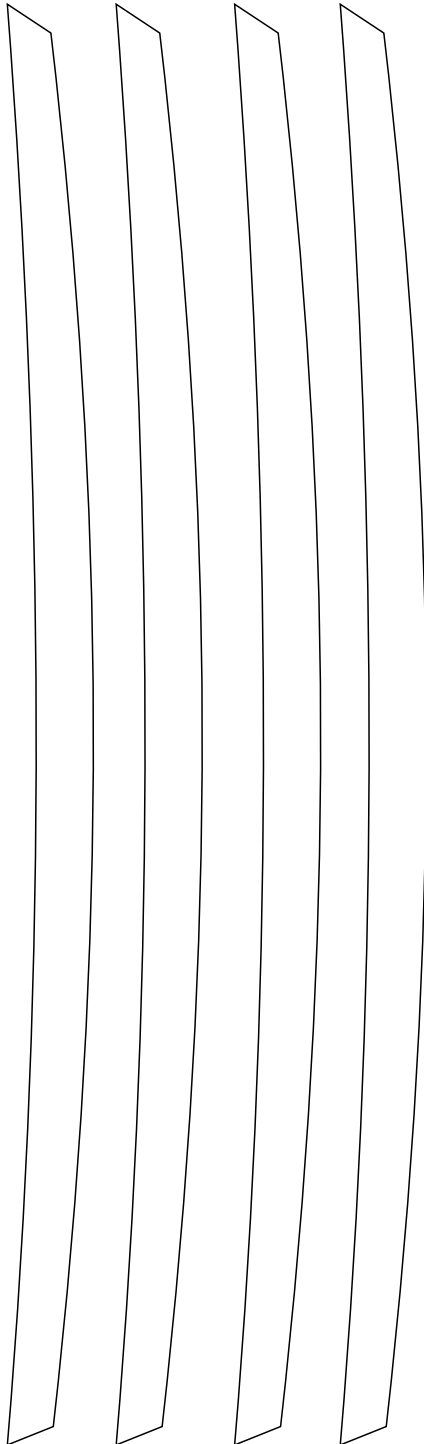
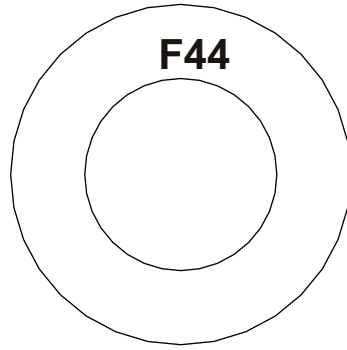
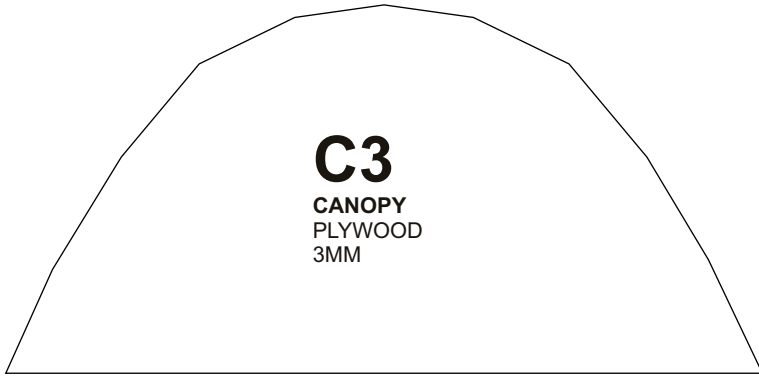

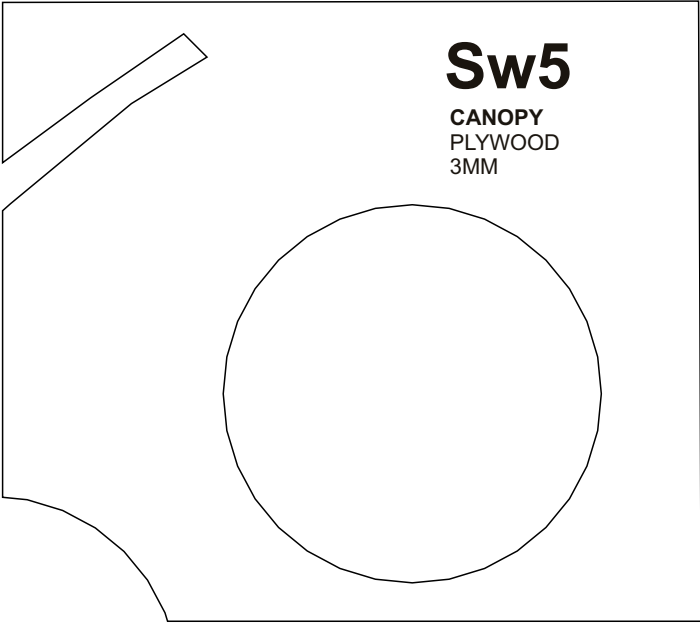
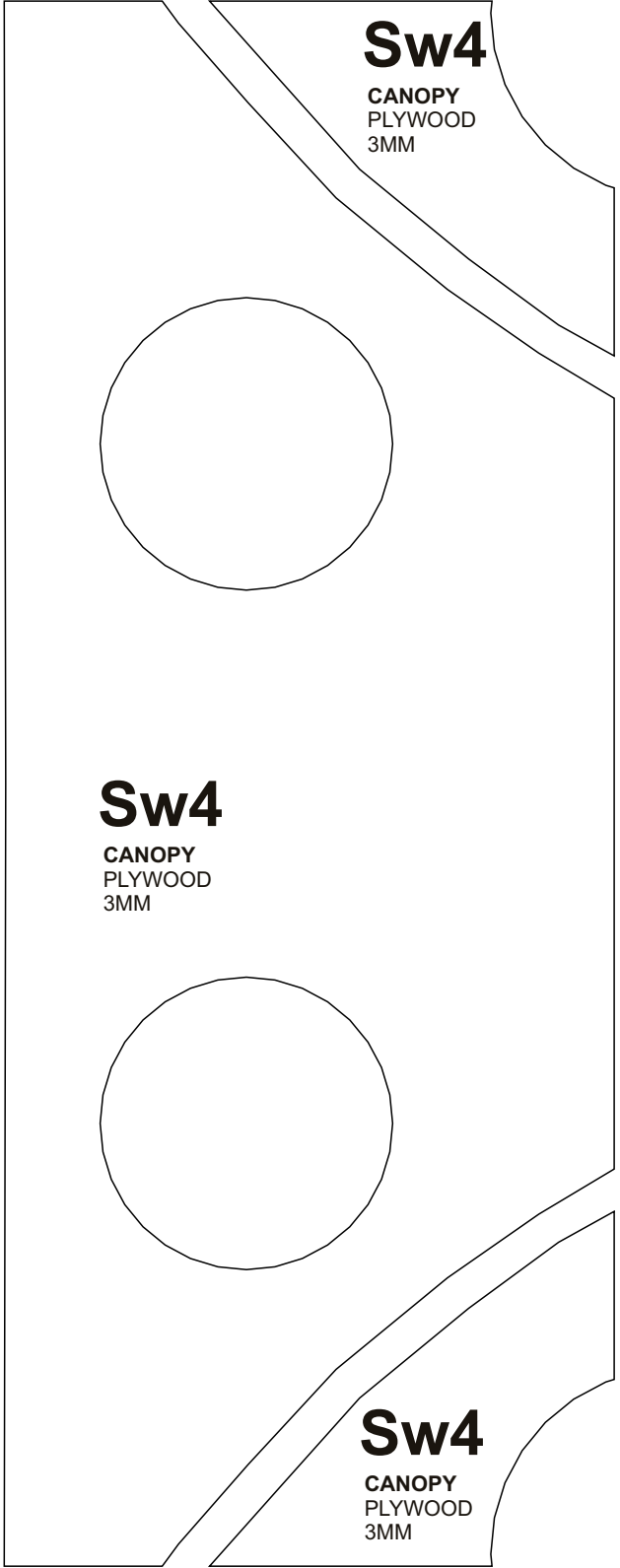
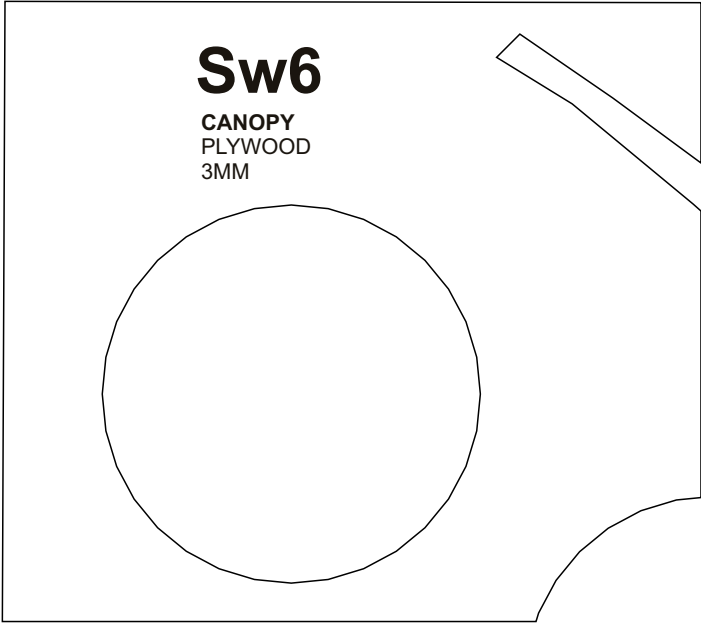

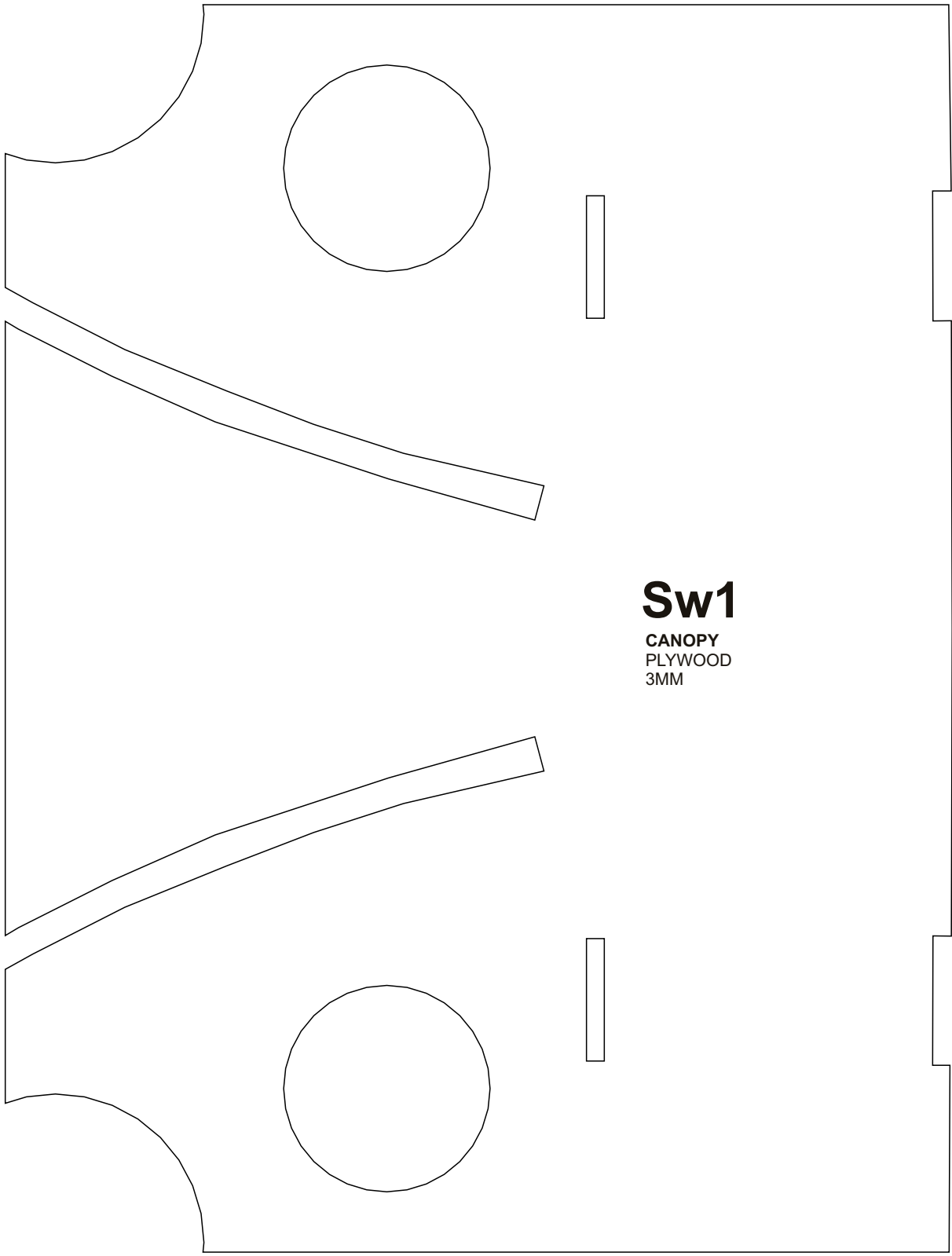

Sw1
CANOPY
PLYWOOD
3MM

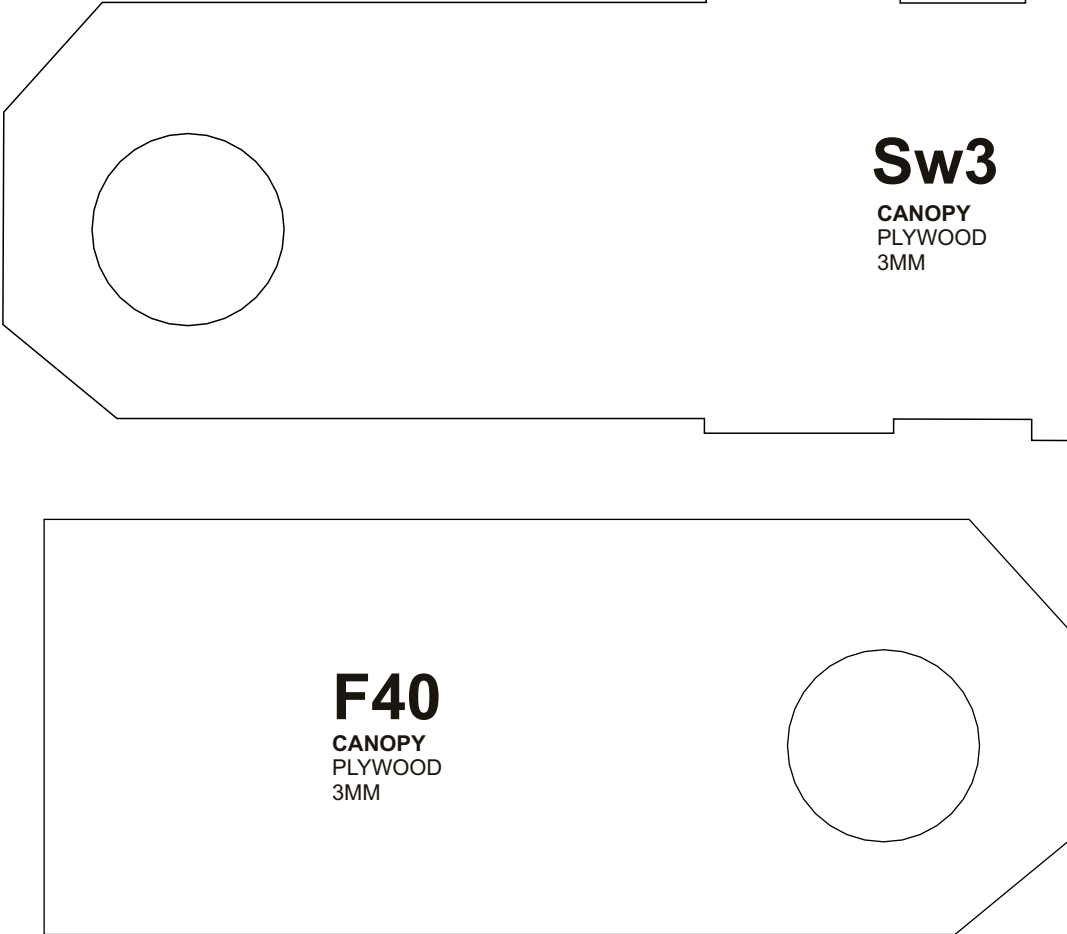
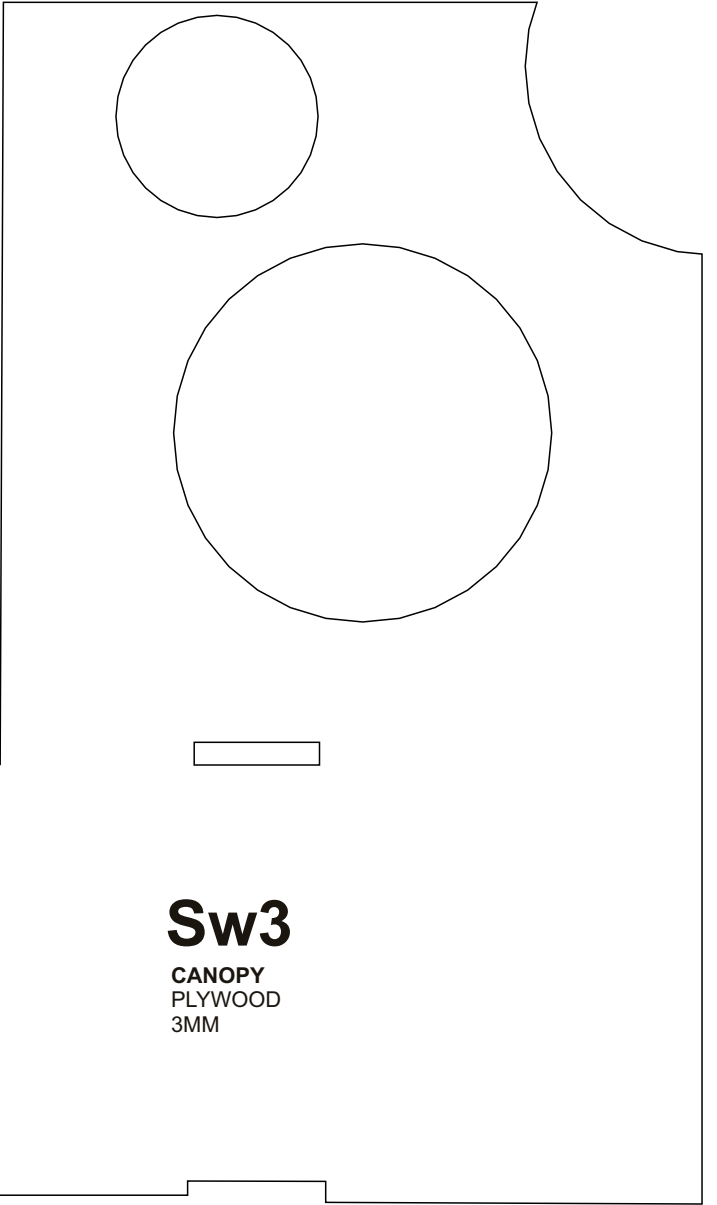
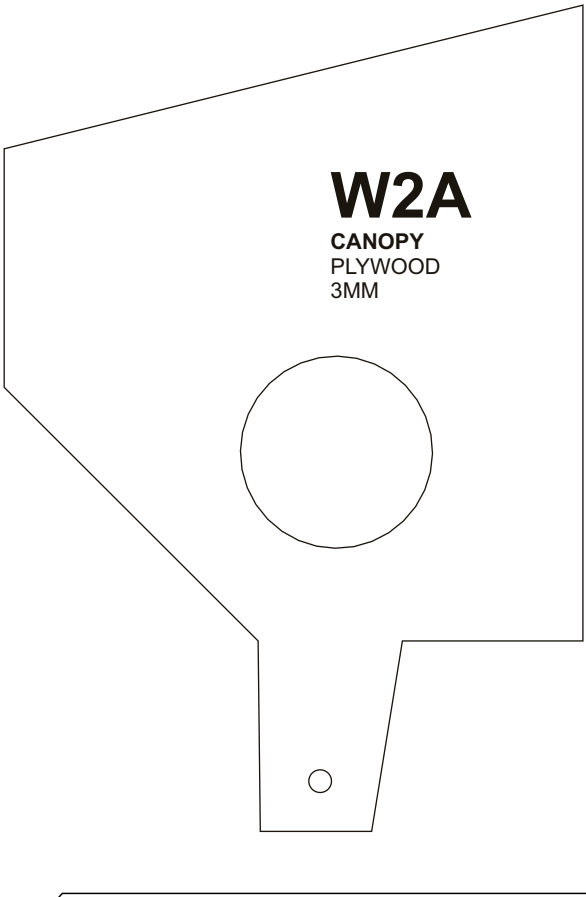

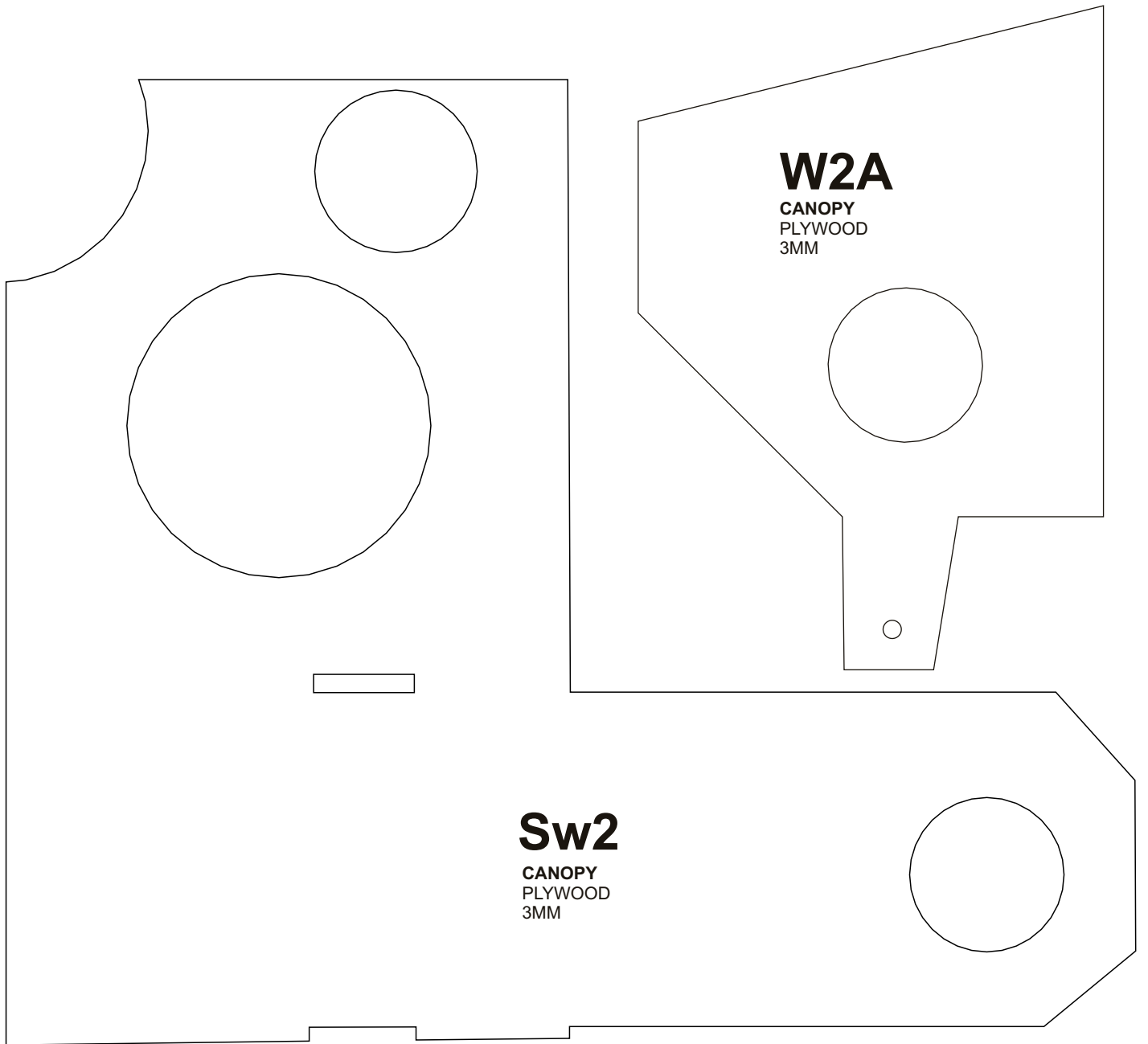

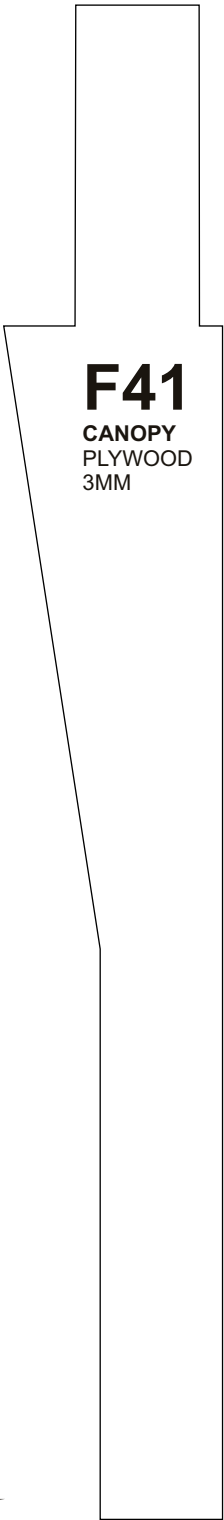
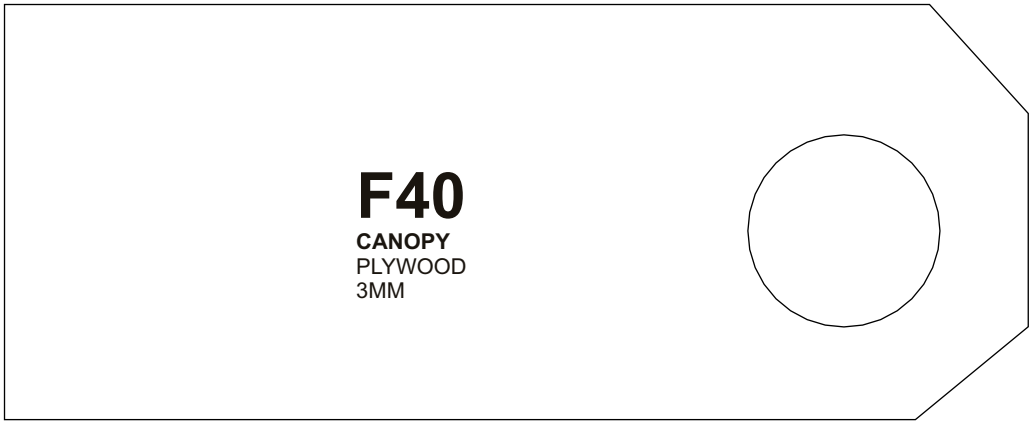
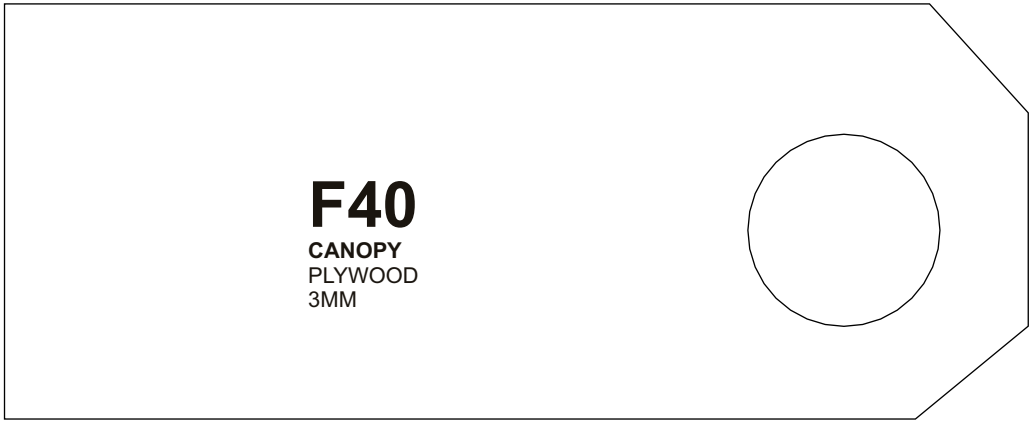
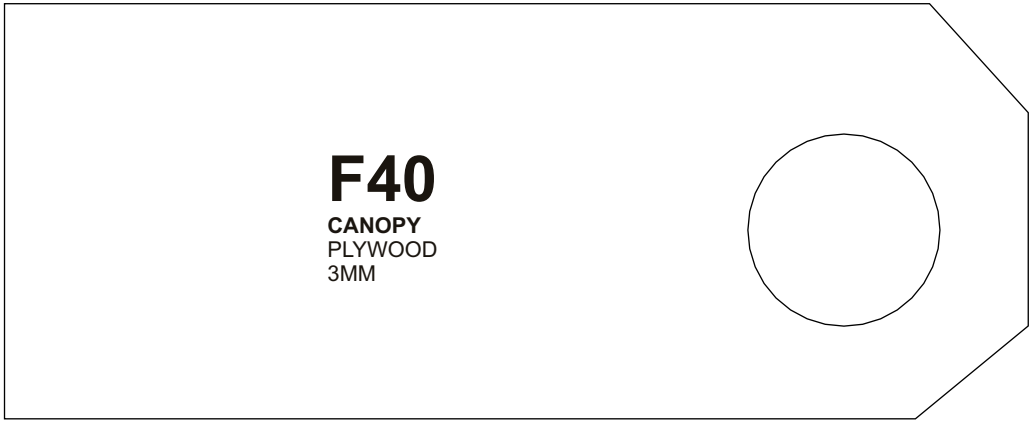

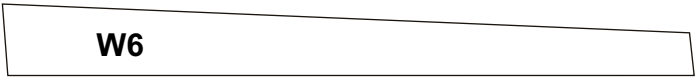
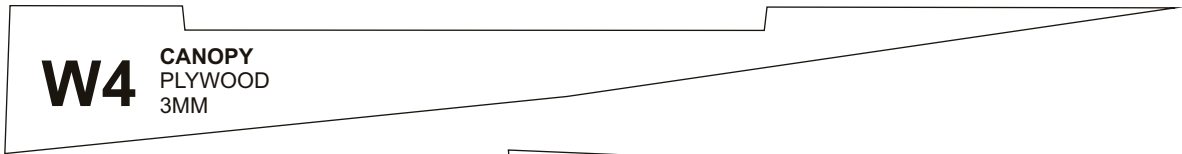
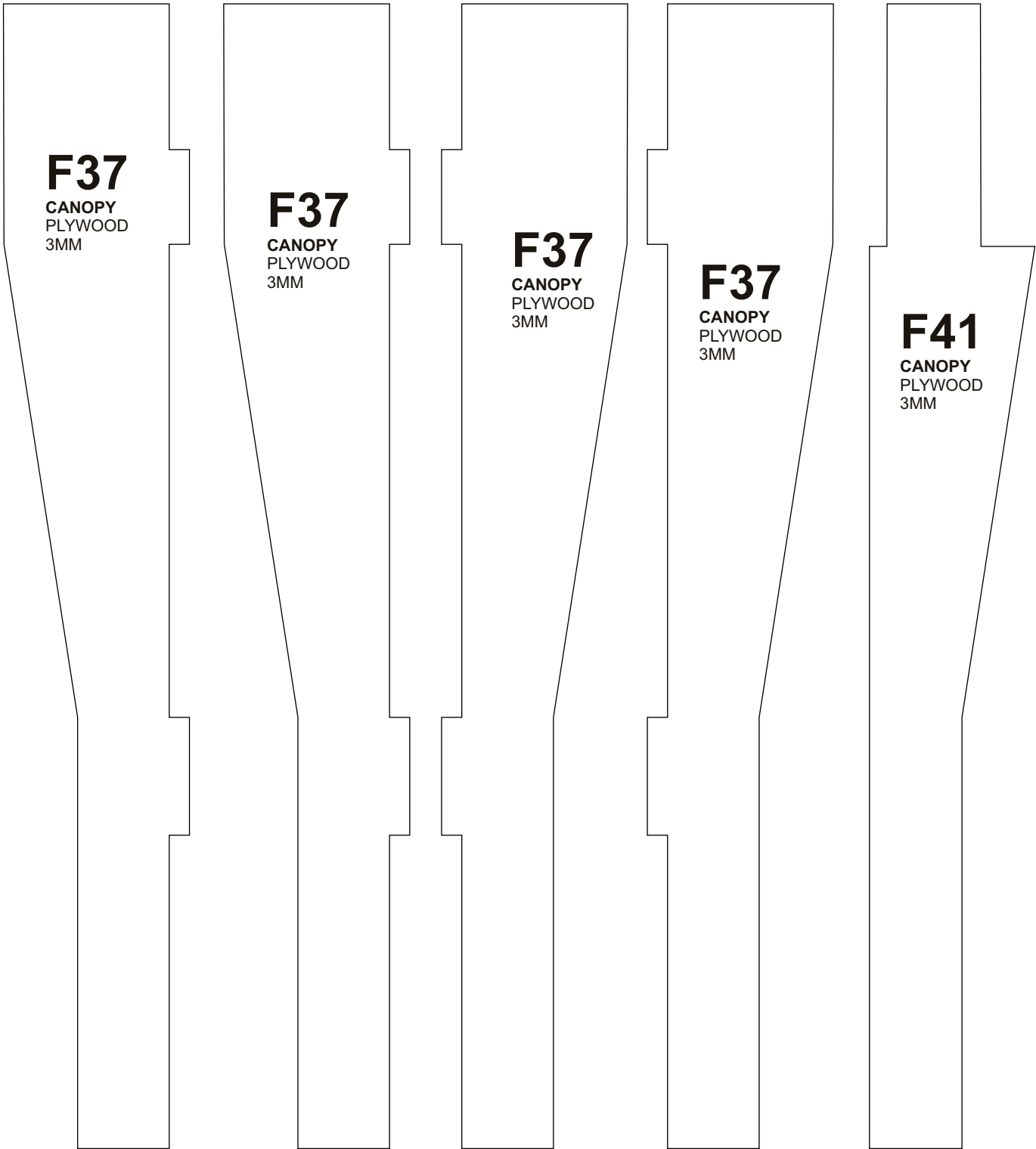

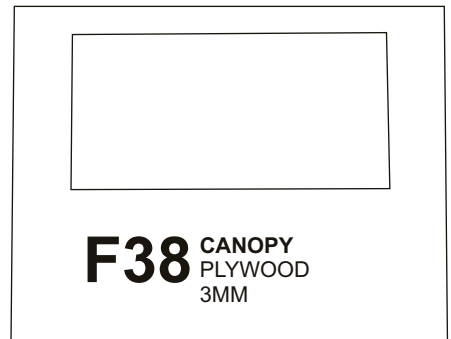
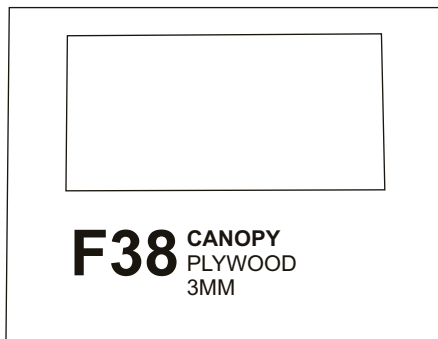
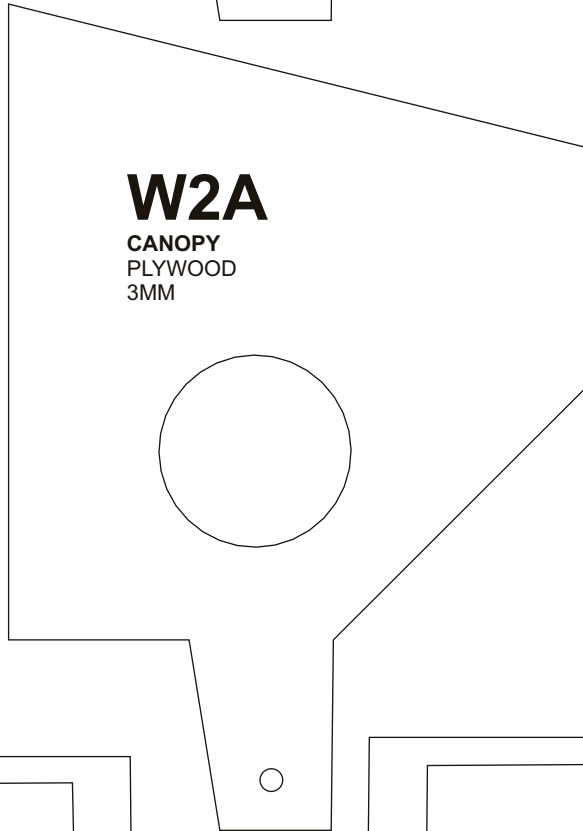
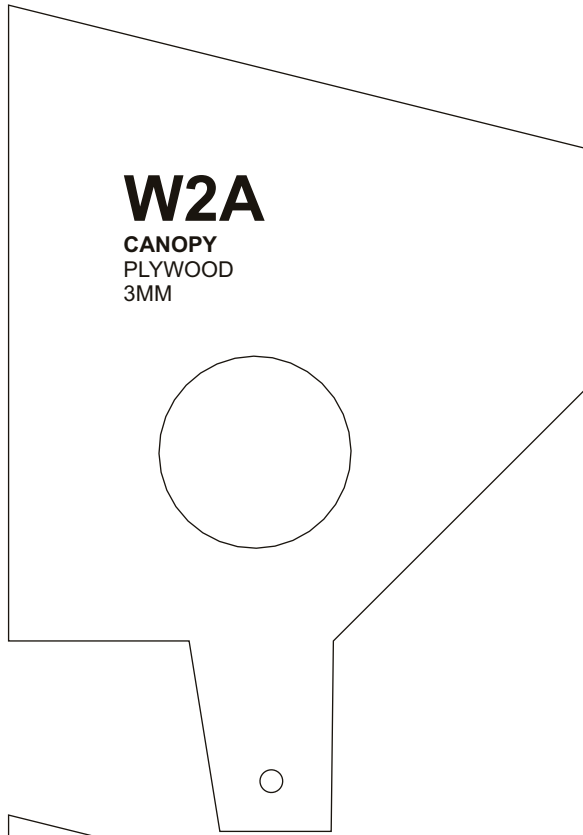
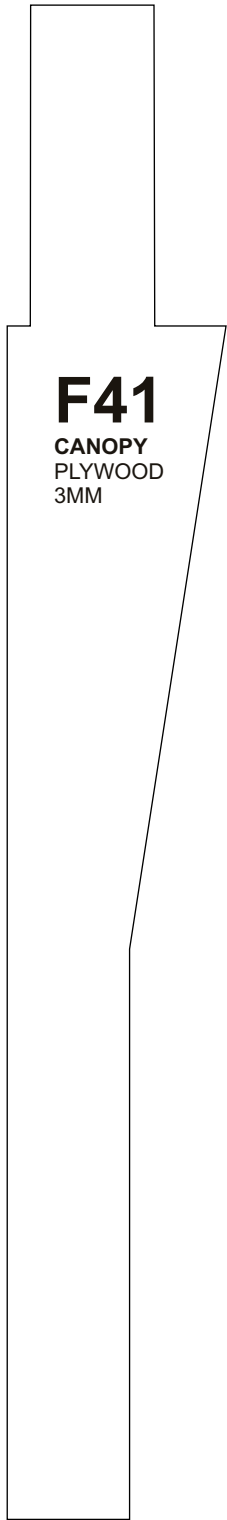
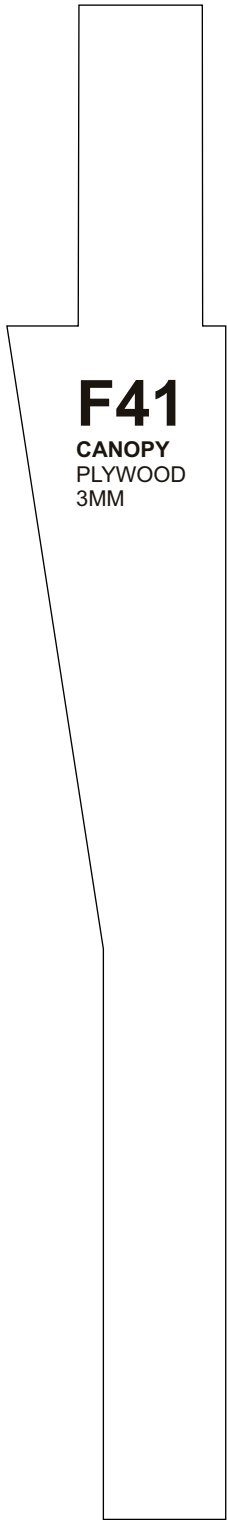

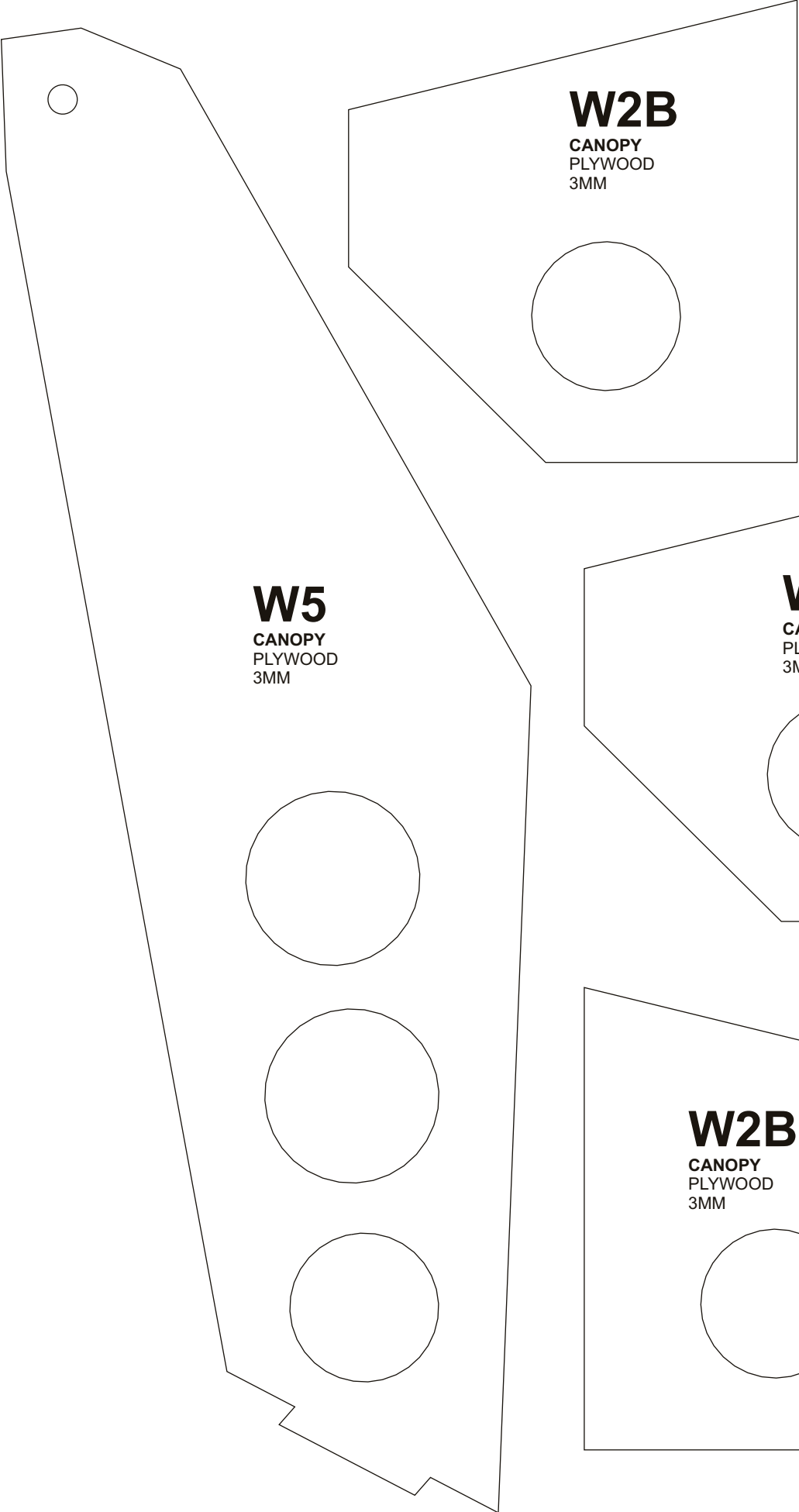

W5
CANOPY
PLYWOOD
3MM

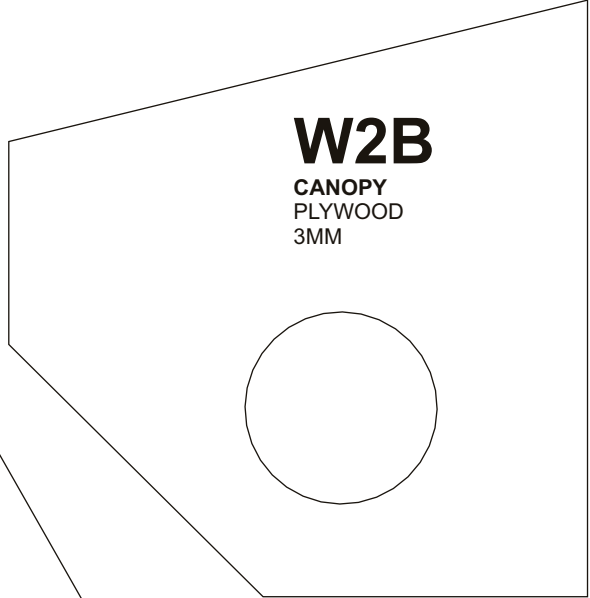

W2B
CANOPY
PLYWOOD
3MM

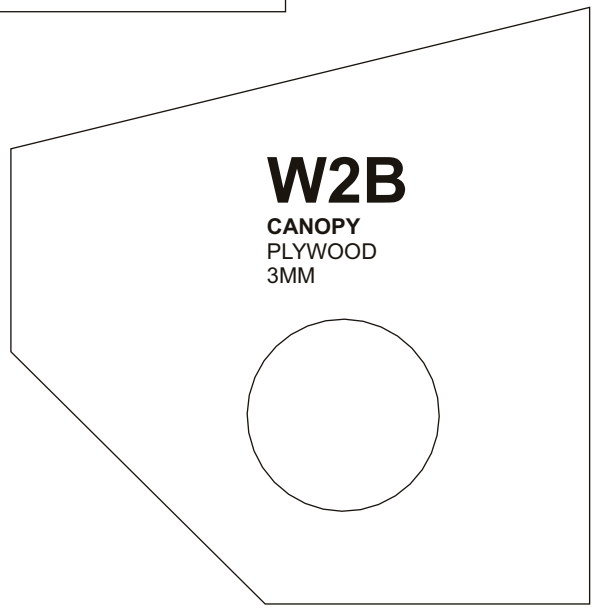

W2B
CANOPY
PLYWOOD
3MM

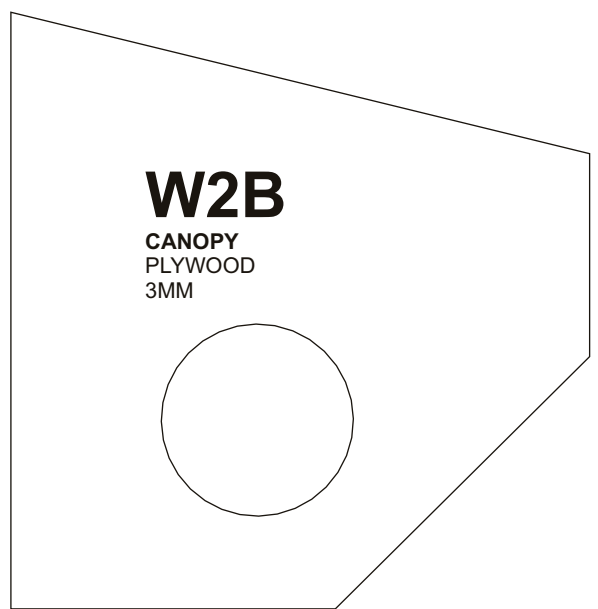

W2B
CANOPY
PLYWOOD
3MM

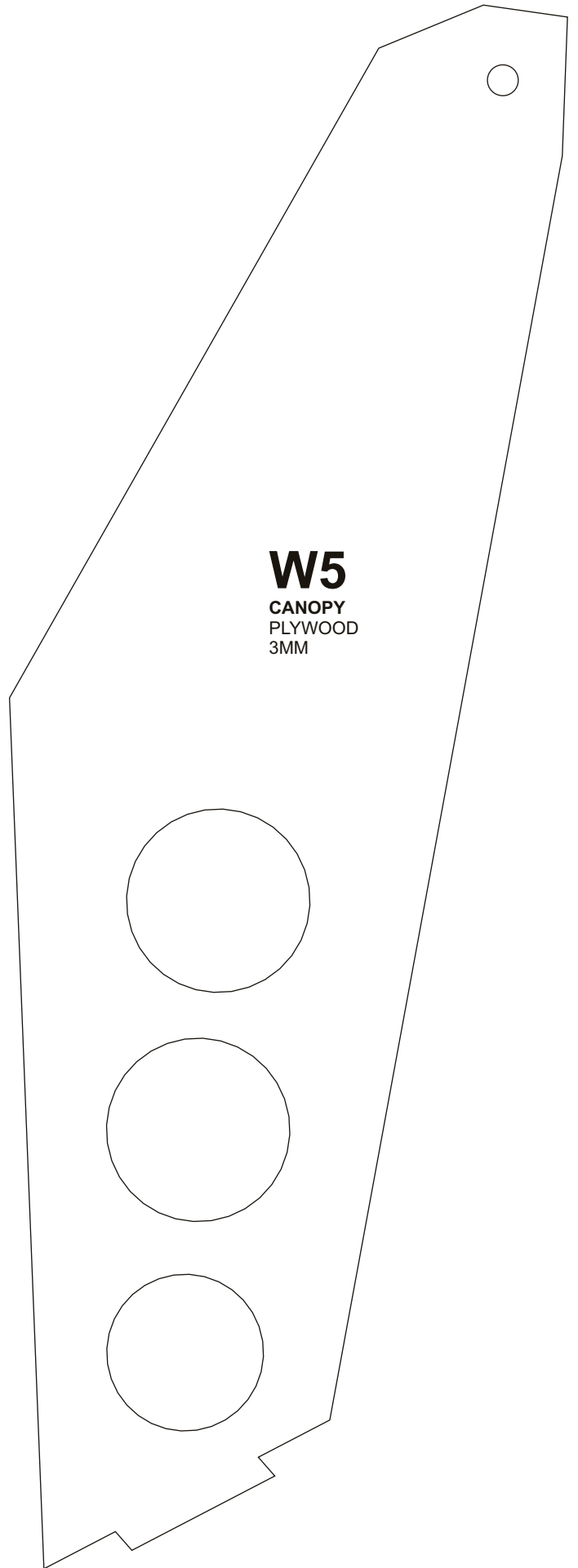
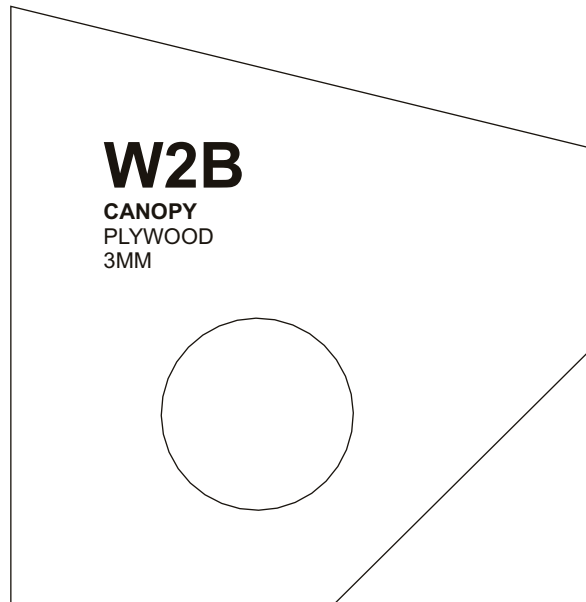
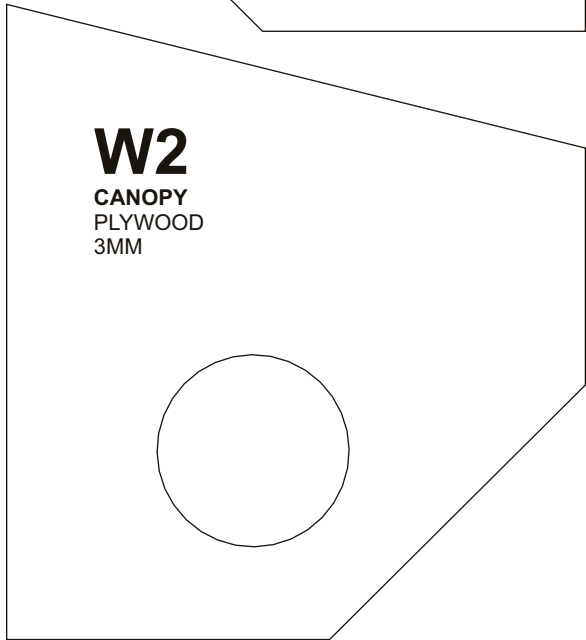
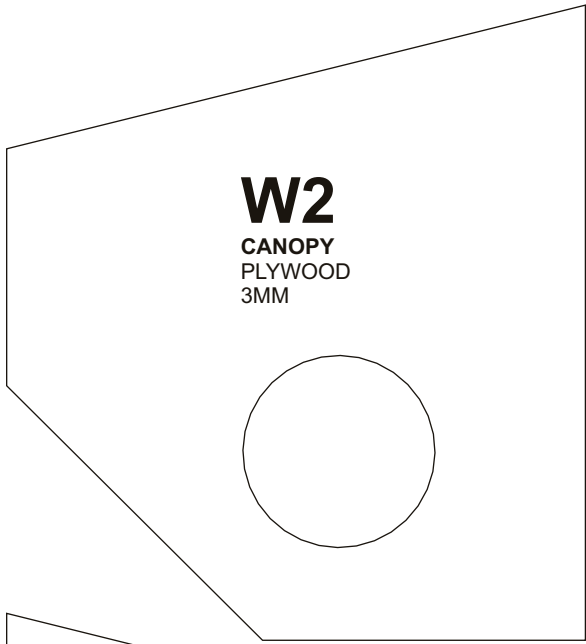

G1

LG BASE
PLYWOOD 3MM

G1

LG BASE
PLYWOOD 3MM

G1

LG BASE
PLYWOOD 3MM

F23

EDF MOUNTING
PLYWOOD 3MM
6X

F23

EDF MOUNTING
PLYWOOD 3MM
6X

F23

EDF MOUNTING
PLYWOOD 3MM
6X

F23

EDF MOUNTING
PLYWOOD 3MM
6X

F23

EDF MOUNTING
PLYWOOD 3MM
6X

F23

EDF MOUNTING
PLYWOOD 3MM
6X

G1

LG BASE
PLYWOOD 3MM

